

# VocoPro<sup>®</sup>

PROFESSIONAL VOCAL SYSTEMS<sup>™</sup>

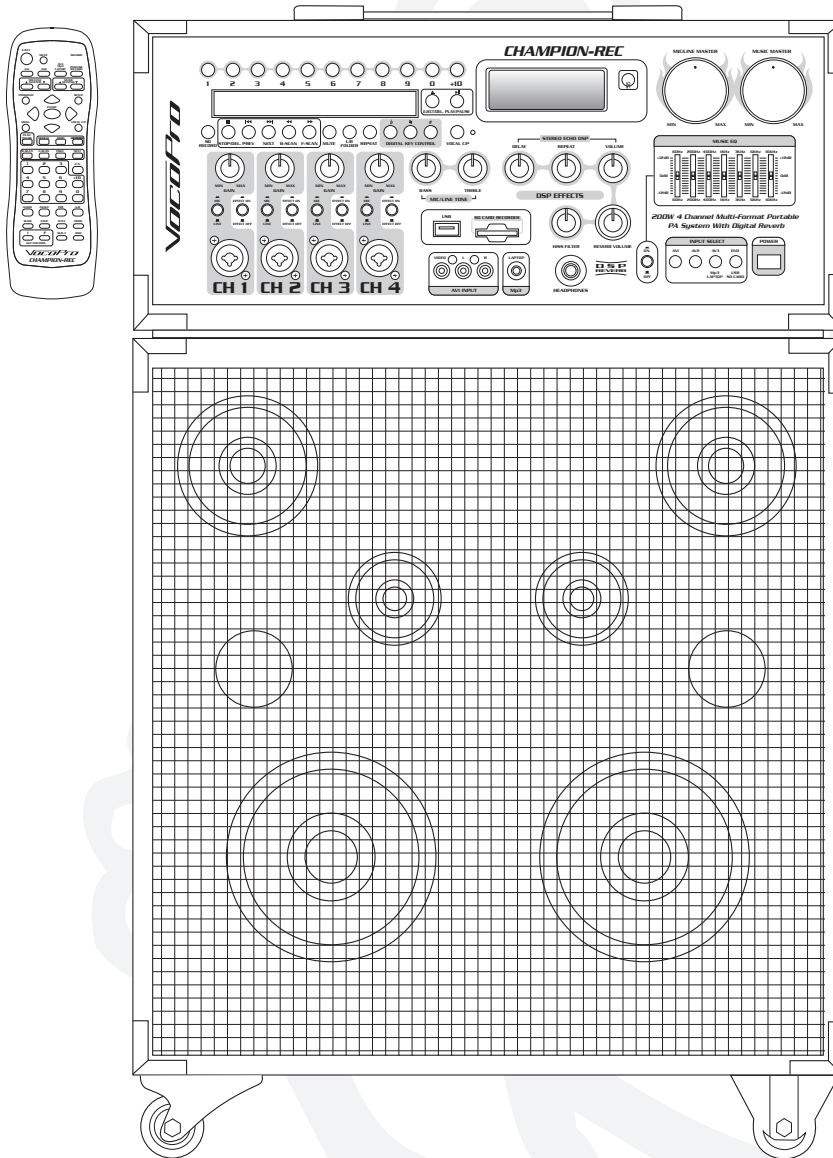

## **CHAMPION-REC**

Portable Mini-Concert System  
with Digital Recorder

o w n e r ' s m a n u a l

# Table of Contents

|                                     |    |
|-------------------------------------|----|
| Important Safety Instructions ..... | 3  |
| Listening for a Lifetime.....       | 4  |
| Welcome .....                       | 5  |
| Features .....                      | 6  |
| Getting Started .....               | 7  |
| Getting Connected .....             | 8  |
| Descriptions and Functions          |    |
| Front Panel.....                    | 14 |
| Rear Panel .....                    | 18 |
| Remote Control.....                 | 19 |
| Basic Operations.....               | 21 |
| Setup Menu .....                    | 25 |
| Troubleshooting .....               | 27 |

# Important Safety Instructions



## CAUTION RISK OF SHOCK



CAUTION: To reduce the risk of electric shock, do not remove cover (or back). No user-serviceable parts inside. Only refer servicing to qualified service personnel.

Protect the power cord from being walked on or pinched particularly at the plugs, convenience receptacles, and at the point where they exit from the apparatus.

Only use attachments/accessories specified or provided by the manufacturer (such as the exclusive supply adapter, battery etc).

## Explanation of Graphical Symbols



The lightning flash & arrowhead symbol, within an equilateral triangle, is intended to alert you to the presence of danger.



The exclamation point within an equilateral triangle is intended to alert you to the presence of important operating and servicing instructions.

## WARNING

To reduce the risk of fire or electric shock, do not expose this unit to rain or moisture.



Use only with the cart, stand, tripod, bracket, or table specified by the manufacturer, or sold with the apparatus. When a cart or rack is used, use caution when moving the cart/apparatus combination to avoid injury from tip-over.

Unplug the apparatus during lightning storms or when unused for long periods of time.

Refer all servicing to qualified personnel. Servicing is required when the apparatus has been damaged in any way, such as power supply cord or plug is damaged, liquid has been spilled or objects have fallen into the apparatus has been exposed to rain or moisture, does not operate normally, or has been dropped.

Please keep the unit in a good ventilation environment.

Read these instructions.

Keep these instructions.

Heed all warnings.

Follow all instructions.

Do not use this apparatus near water.

Clean only with dry cloth.

Do not block any ventilation openings. Install in accordance with the manufacturer's instructions.

Do not install near any heat sources such as radiators, heat registers, stoves, or other apparatus (including amplifiers) that produce heat.

Do not defeat the safety purpose of the polarized or grounding plug. A polarized plug has two blades with one wider than the other. A grounding plug has two blades and a third grounding prong. The wide blade or the third prong is provided for your safety. If the provided plug does not fit into your outlet, consult an electrician for replacement of the obsolete outlet.

### Note:

To CATV system installer's (U.S.A.): This reminder is provided to call the CATV system installer's attention to Article 820-40 of the NEC that provides guidelines for proper grounding and, in particular, specifies that the cable ground shall be connected as close to the point of cable entry as practical.

# Listening for a Lifetime

Selecting fine audio equipment such as the unit you've just purchased is only the start of your musical enjoyment. Now it's time to consider how you can maximize the fun and excitement your equipment offers. VocoPro and the Electronic Industries Association's Consumer Electronics Group want you to get the most out of your equipment by playing it at a safe level. One that lets the sound come through loud and clear without annoying blaring or distortion and, most importantly, without affecting your sensitive hearing.

Sound can be deceiving. Over time your hearing "comfort level" adapts to a higher volume of sound. So what sounds "normal" can actually be loud and harmful to your hearing. Guard against this by setting your equipment at a safe level BEFORE your hearing adapts.

To establish a safe level:

- Start your volume control at a low setting.
- Slowly increase the sound until you can hear it comfortably and clearly, and without distortion.

Once you have established a comfortable sound level:

- Set the dial and leave it there.
- Pay attention to the different levels in various recordings.

Taking a minute to do this now will help to prevent hearing damage or loss in the future. After all, we want you listening for a lifetime.

Used wisely, your new sound equipment will provide a lifetime of fun and enjoyment. Since hearing damage from loud noise is often undetectable until it is too late, this manufacturer and the Electronic Industries Association's Consumer Electronics Group recommend you avoid prolonged exposure to excessive noise. This list of sound levels is included for your protection.

## Some common decibel ranges:

| Level     | Example   |
|-----------|---|
| <b>30</b> | Quiet library, Soft whispers                                  |
| <b>40</b> | Living room, Refrigerator, Bedroom away from traffic          |
| <b>50</b> | Light traffic, Normal Conversation                            |
| <b>60</b> | Air Conditioner at 20 ft., Sewing machine                     |
| <b>70</b> | Vacuum cleaner, Hair dryer, Noisy Restaurant                  |
| <b>80</b> | Average city traffic, Garbage disposals, Alarm clock at 2 ft. |

## The following noises can be dangerous under constant exposure:

| Level      | Example                                       |
|------------|---|
| <b>90</b>  | Subway, Motorcycle, Truck traffic, Lawn Mower |
| <b>100</b> | Garbage truck, Chainsaw, Pneumatics drill     |
| <b>120</b> | Rock band concert in front of speakers        |
| <b>140</b> | Gunshot blast, Jet plane                      |
| <b>180</b> | Rocket launching pad                          |

-Information courtesy of the Deafness Research Foundation



# Welcome

And thank you for purchasing the **CHAMPION-REC** from VocoPro, your ultimate choice in Karaoke entertainment! With years of experience in the music entertainment business, VocoPro is a leading manufacturer of Karaoke equipment, and has been providing patrons of bars, churches, schools, clubs and individual consumers the opportunity to sound like a star with full-scale club models, in-home systems and mobile units. All our products offer solid performance and sound reliability, and to reinforce our commitment to customer satisfaction, we have customer service and technical support professionals ready to assist you with your needs. We have provided some contact information for you below.

## VocoPro

1728 Curtiss Court  
La Verne, CA 91750

**Toll Free: 800-678-5348**

TEL: 909-593-8893

FAX: 909-593-8890

### VocoPro Company Email Directory

#### Customer Service & General Information

info@vocopro.com

#### Tech Support

techsupport@vocopro.com

#### Remember Our Website

Be sure to visit the VocoPro website **www.vocopro.com** for the latest information on new products, packages and promos. And while you're there don't forget to check out our Club VocoPro for Karaoke news and events, chat rooms, club directories and even a KJ Service directory!

We look forward to hearing you sound like a PRO, with VocoPro, the singer's ultimate choice.

## FOR YOUR RECORDS

Please record the model number and serial number below, for easy reference, in case of loss or theft. These numbers are located on the rear panel of the unit. Space is also provided for other relevant information

**Model Number**

**Serial Number**

**Date of Purchase**

# Features

A Portable Mini-Concert System for the Road.

Whether you are a traveling musician on the road, a vocalist that needs to do a gig, or an aspiring singer who wants to practice at home, VocoPro has the perfect audio solution for you, the CHAMPION-REC mini-concert system.

It's a compact two-piece system with a powerful 200W 6-speaker stereo system that sets up in seconds. Hosting pro-level features such as a 4 channel mic/line mixer with DSP Reverb, and Hiss Filtering, you can count on your sound being top-notch. The on-board SD card slot is not only a MP3/WMA player; it is also a digital recorder. The digital recordings are high-quality and can be easily ported to a computer for cataloging and creating demo discs.

Use this as the main stage system in a coffee shop, or connect to a house system for an outdoor concert. Either way, you will have the built-in effects and monitor controls at your fingertips.

So, if you are looking for a handy, portable mini-concert system that you can easily take on the go, try the CHAMPION-REC and experience the sound quality and convenience of an awesome all-in-one sound system.

- Two-Piece Design Pumps a Powerful 200W Through a 6-Speaker Cabinet
- Built-in Digital SD Recorder
- Remove Head for Easy Transport and Integration with House Systems
- Speaker Cabinet Can Be Rotated to Face the Audience for Performances
- Multi-Format Player Supports Standard CD, CD+G, DVD, VCD, Mp3, AVI, Photo-CD, and Most CD-R/CD-RW Formats
- Four Professional 1/4"/XLR Mic/Line Inputs with DSP Reverb & Effect On/Off Switches
- USB Port and SD Card Slot for Accessing Your Favorite Tracks on USB jumpdrives and SD Cards
- 7-Band Equalizer for Customizing the Sound of Your Music
- Handy Front Panel A/V & 1/8" Laptop/Mp3 Input for the Ultimate Entertainment Experience
- 13-Step Digital Key Control to Adjust the Key of Your Disc Audio
- Two Wireless Receiver Slots on Rear Panel Support up to 2 Wireless Modules for a Total of 4 Wireless Microphones\*
- \*Additional wireless microphone module and wireless microphones sold separately.
- Full-Function Remote Control
- 120V/240V and NTSC/PAL Compatible for Worldwide Use

# Getting Started

Thank you for purchasing the CHAMPION-REC. Take a few moments to look through this manual. Before setting up, please make sure the following items are included.

- CHAMPION-REC
- Remote Control
- 2 Speaker Cables
- RCA Cable
- 1/8" Stereo Audio Cable
- Power Cable

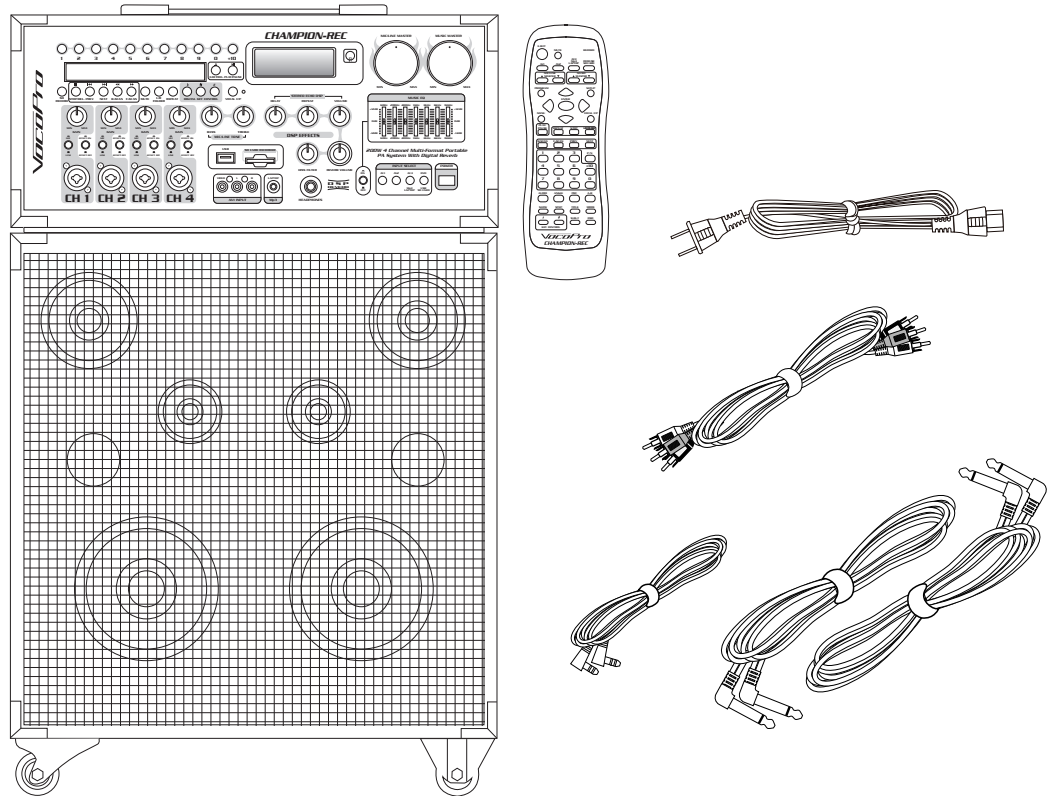
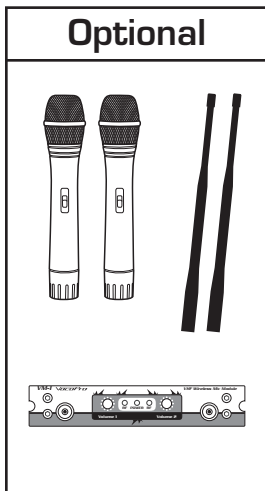

## Returns and Warranty

In the unlikely event that the CHAMPION-REC would need to be shipped for repair, it is recommended that you keep all the product packaging and receipt. For detailed warranty information, please visit [www.vocopro.com/warranty\\_extended.html](http://www.vocopro.com/warranty_extended.html). To find a VocoPro Authorized Service Center near you, please visit [www.vocopro.com/servicecenter.html](http://www.vocopro.com/servicecenter.html)

# Getting Connected

The CHAMPION-REC is an all-in-one unit, but has plenty of connections to incorporate it into any setup. The diagram below shows some optional connections.

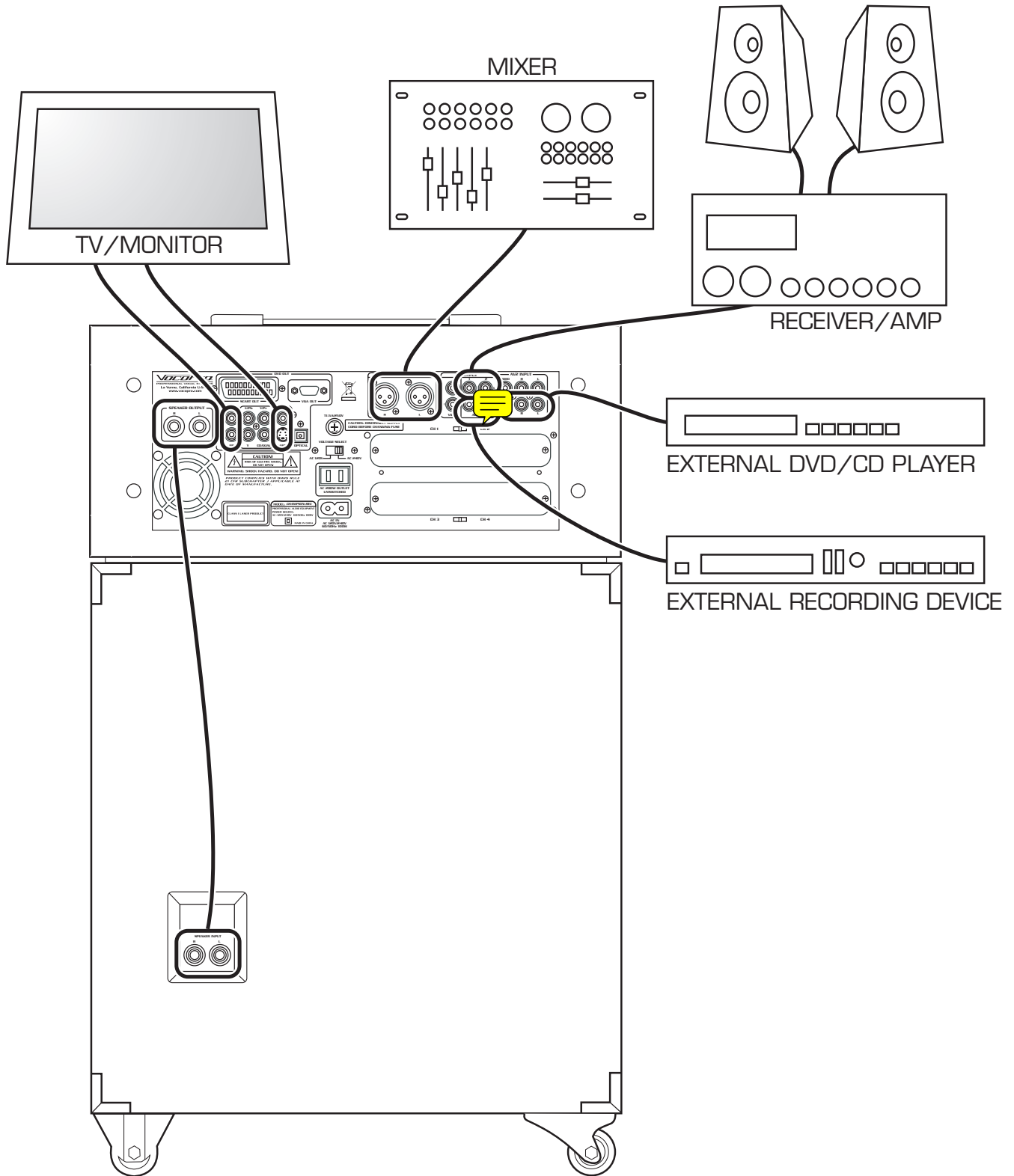



# Getting Connected

The CHAMPION-REC can be connected to an Mp3 player or computer using the 1/8" input on the front panel. To connect a Laptop/Mp3 player, see your Laptop/Mp3 player instructions on connecting to a 1/8" input. To connect a computer, use a 1/8" to 1/8" inch cable to connect the computer line out to the CHAMPION-REC 1/8" input.

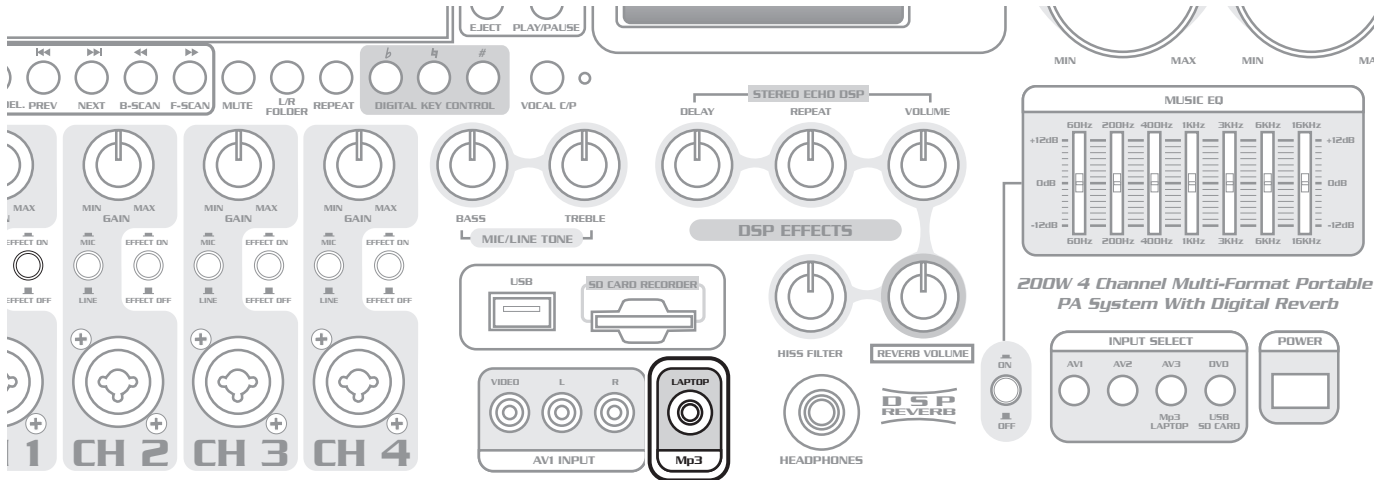

## CABLE USED

1/8" to 1/8" Audio Cable

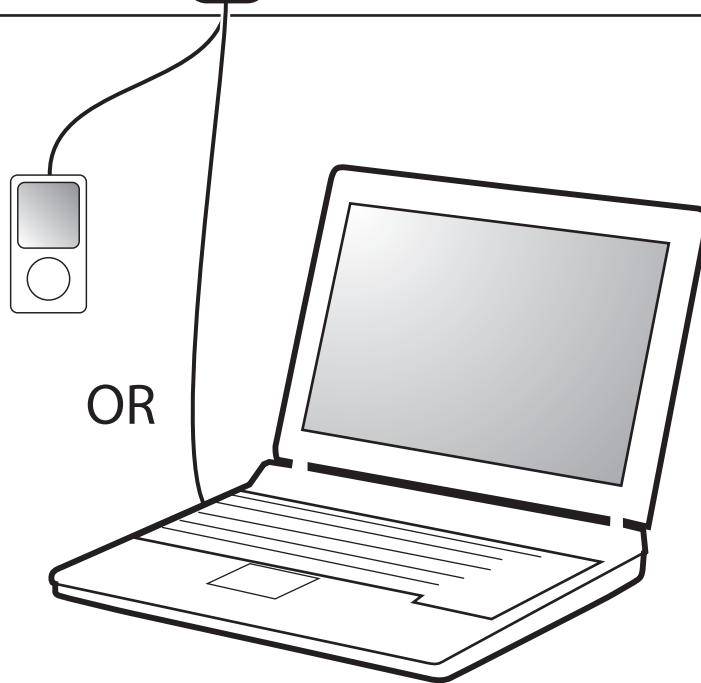

# Getting Connected

## AV INPUT CONNECTIONS

To connect an external AV device such as a mixer or player, use RCA-type AV cables for all connections.

For AUDIO, connect the L and R AUDIO OUTPUT jacks from the source player to the L (white) and R (red) AUDIO INPUT jacks on the CHAMPION-REC using one of the two AV channels of your choice.

For VIDEO, connect the VIDEO OUTPUT jack on the source player to the yellow VIDEO INPUT jack on the CHAMPION-REC, using the same channel you connected the audio to.

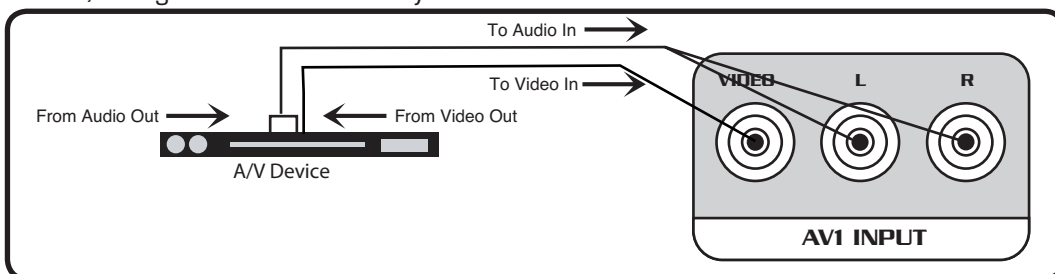

## AUDIO OUTPUT CONNECTIONS

To output audio to external devices, there are three available jacks: AUDIO OUTPUT 1 & 2 (RCA) and BALANCED AUDIO OUTPUT (XLR). All three outputs can be connected simultaneously.

For AUDIO OUTPUT 1 & 2, using an RCA-type audio cable, connect the left and right AUDIO/LINE/AUX INPUT jacks on the external device to the left and right AUDIO OUTPUT 1 or 2 jacks on the CHAMPION-REC.

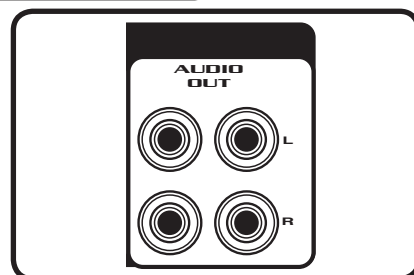

For BALANCED AUDIO OUTPUT, using two XLR-type audio cables, connect the left and right AUDIO/LINE IN jacks on the external device to the left and right BALANCED AUDIO OUTPUT jacks on the CHAMPION-REC's rear panel.

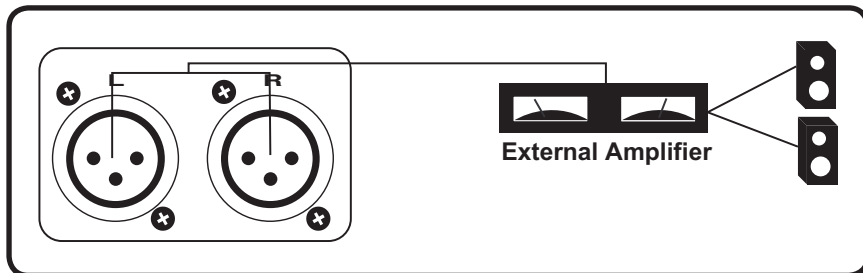

## VIDEO OUTPUT CONNECTIONS

The CHAMPION-REC has two RCA-type VIDEO OUTPUT jacks for connecting to TVs or monitor devices.

Connecting to a TV with an RCA Connection

Using either the yellow RCA plug from the included RCA patch cable or a separate RCA patch cable, connect one end to the RCA VIDEO OUTPUT jack on the CHAMPION-REC and connect the other end to the VIDEO INPUT jack on your TV or monitor device. Both VIDEO OUTPUTS can be connected simultaneously.

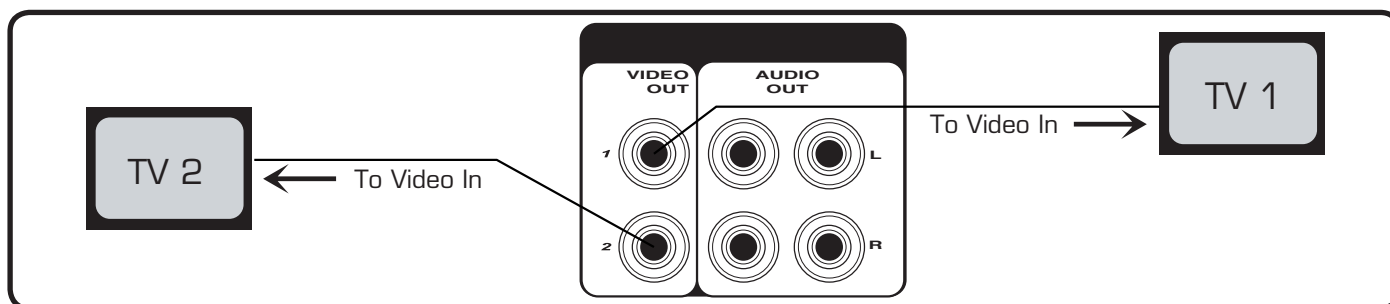

# Getting Connected

## Connecting to a TV with Component Video

Using 3 appropriate Component Video cables (usually color coded red, blue and green), connect a set of plugs to the COMPONENT VIDEO OUT jacks (Y-U/Pb-V/Pr) on the CHAMPION-REC and plug the other set of plugs to the COMPONENT VIDEO IN jacks (Y-U/Pb-V/Pr) on your television. On some TVs, the component video input jacks may be labeled differently (i.e. Pr/Pb/Y or Cr/Cb/Y or R-Y/B-Y/Y etc.). You will need to press the MODE button on the remote control to toggle between YUV for Component Video, RGB for Composite Video and S-Video. You can only use the MODE button when there is no disc inserted in the disc tray.

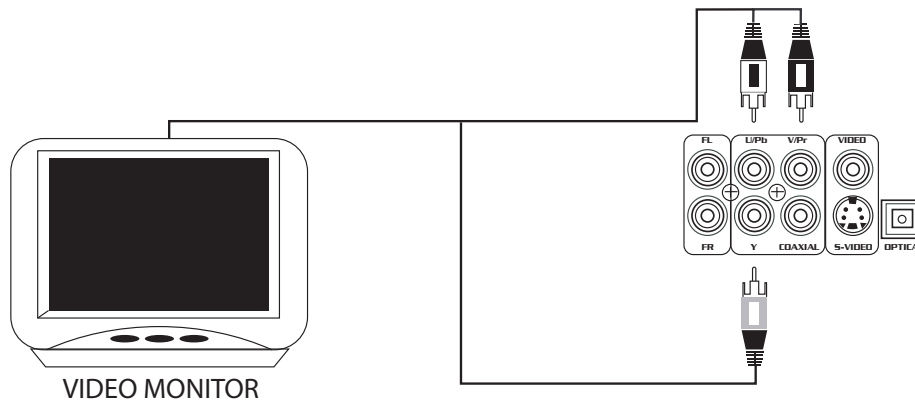

# Getting Connected

## Connecting to a DTS Receiver/Decoder

Using either an RCA-ended COAXIAL cable suited for digital audio use or an OPTICAL cable, connect one end to the appropriate jack on the CHAMPION-REC (COAXIAL or OPTICAL) and the other end to the appropriate jack on the DTS receiver (COAXIAL or OPTICAL).

If you have both coaxial and optical inputs on your DTS decoder/receiver, it is recommended to use an optical connection as those cables eliminate the possibility of EMI (electromagnetic interference).

If your receiver does not have a built-in DTS decoder, and has 5.1 or 7.1 channel RCA inputs, you can use the 5.1 or 7.1 channel output jacks on the CHAMPION-REC. Either method will provide for DTS decoding.

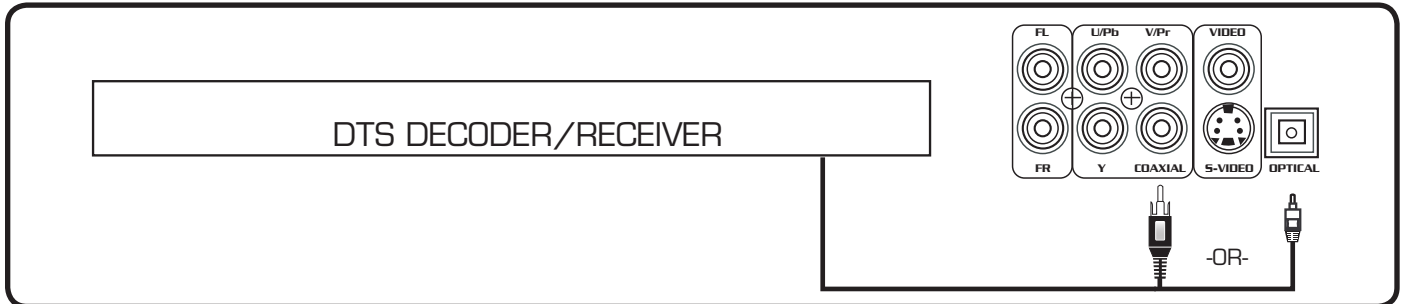

Connecting to a TV or monitor with S-Video.

Using an S-Video cable, connect one end to the CHAMPION-REC's S-VIDEO OUTPUT jack and connect the other end to the S-VIDEO IN jack on your television.

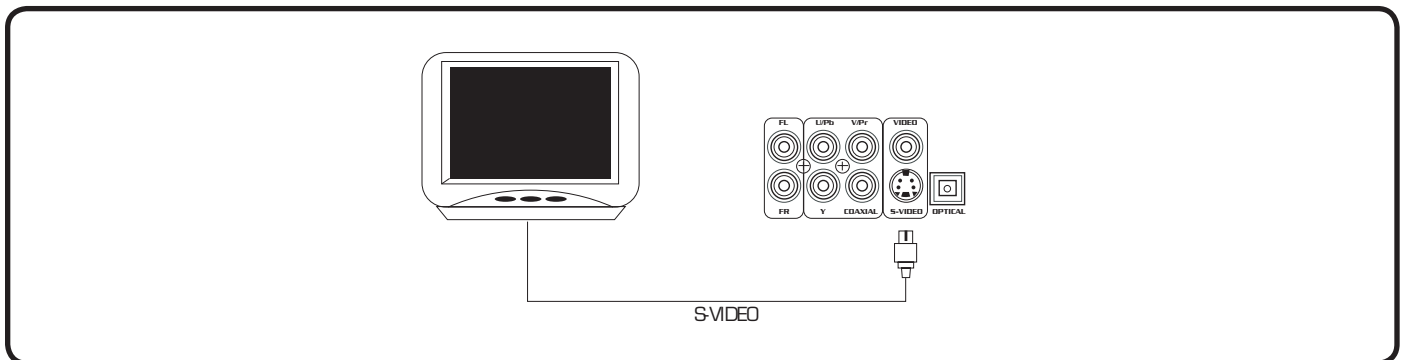

## AC DEVICE CONNECTIONS

The CHAMPION-REC has an AC power outlet on the rear panel to provide power to a connecting device.

**NOTE:** A device with a power consumption rating over 200W should not be connected as that exceeds the allowable power feed. Doing so may cause serious damage to both devices and may void your warranty.

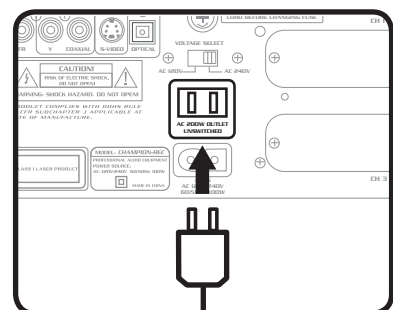

# Getting Connected

## MICROPHONE/INSTRUMENT INPUT CONNECTION

After completing your main system connections, it is time to get your microphones and instruments connected and ready for performing. Before you get started with your connections we recommend that you take the following tips into consideration:

- When connecting instruments, refrain from using low quality or worn cables as they can cause significant noise and loud pops, posing a threat to the system's speakers.
- Use caution when connecting a chain of multiple effects pedals, as the output voltage may change and possibly overload the CHAMPION-REC's input channel.

The CHAMPION-REC has four mic/line inputs (1/4" XLR).

To connect MICROPHONES via 1/4" mic cables, connect the XLR-end of the cable into the MICROPHONE until it locks into place and connect the 1/4" plug into the 1/4" jack on channels 1-4 on the CHAMPION-REC.

To connect MICROPHONES via XLR mic cables, attach the XLR "female" end of the cable into the "male" three prong jack located at the base of your handheld MICROPHONE until it locks into place. Then connect the XLR "male" jack at the other end of the cable into channels 1-4 XLR jacks on the CHAMPION-REC. It should be obvious which sides of your XLR cable are male and female as there is only one possible connection.

To connect a GUITAR, connect a 1/4" instrument cable from the GUITAR's 1/4" output to one of the CHAMPION-REC's 1/4" inputs.

To connect a KEYBOARD, connect a 1/4" instrument cable from the KEYBOARD's 1/4" output to one of the CHAMPION-REC's 1/4" inputs.

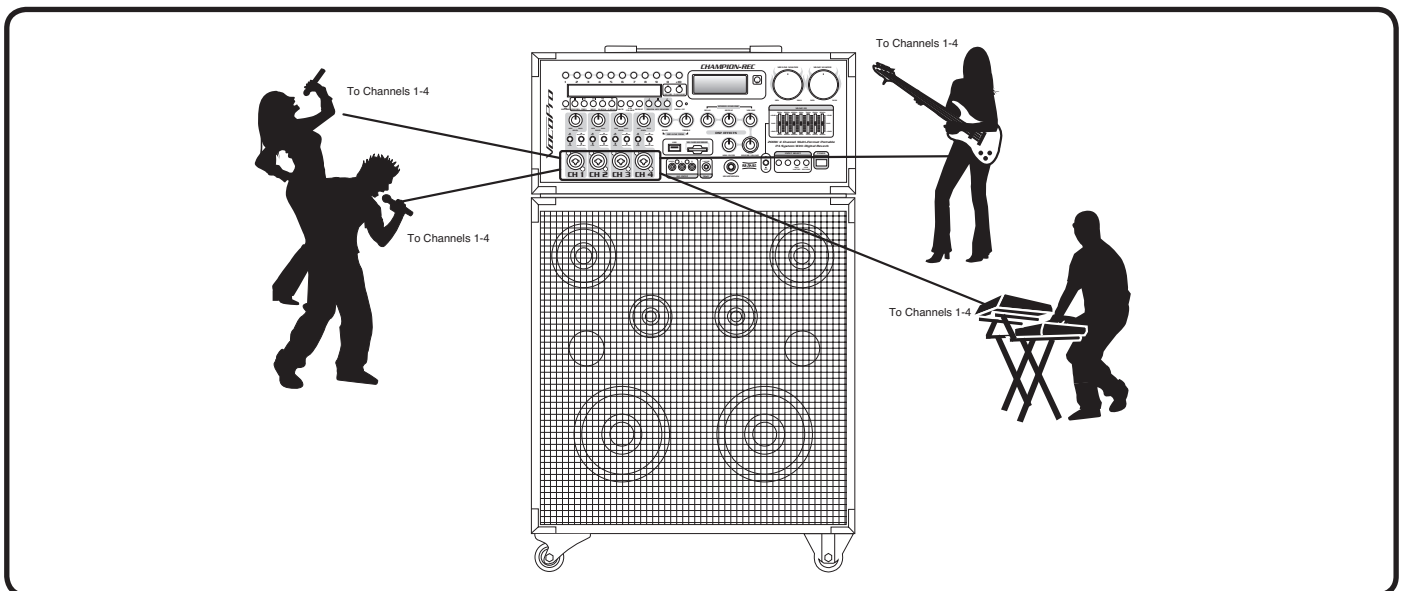

# Descriptions and Functions

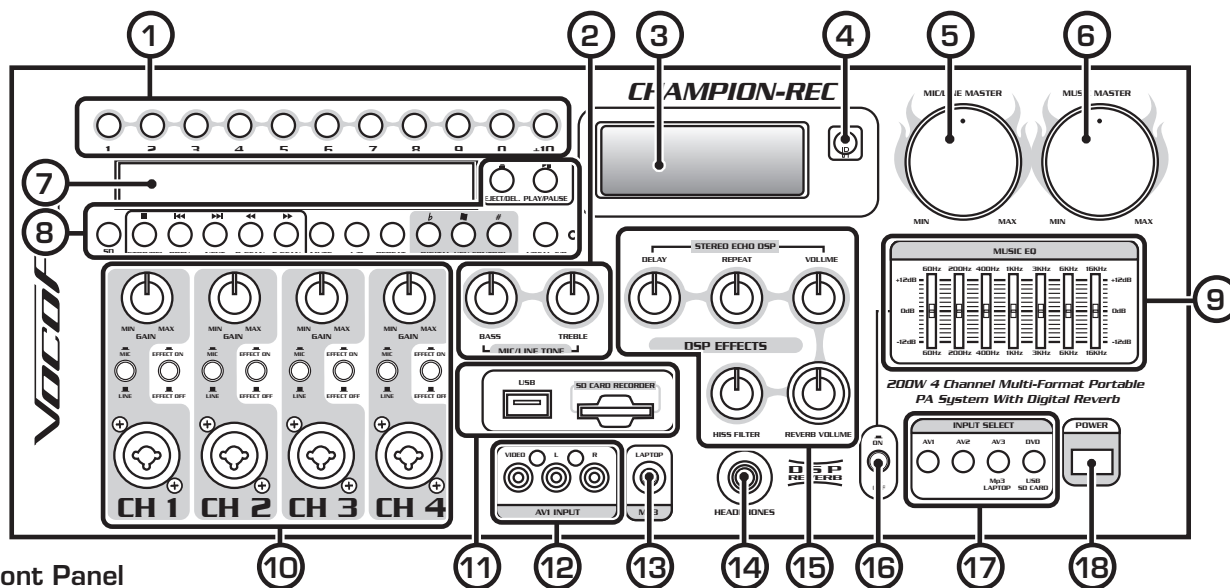

## Front Panel

1. **Direct Track Access Buttons** - In playback mode, use these buttons to jump directly to a track for playback. In radio mode, these buttons set and select radio presets. (See Basic Operations section for more information)
2. **Mic/Line Tone, Bass/Treble Controls** - Use these controls to boost or reduce the amount of bass and treble in the Mic/Line audio. Bass affects the boominess of music, while treble affects the higher pitched clarity. These effects can be switched on and off each input individually using the EFFECT ON/OFF buttons on the Mic/Line channels.
3. **Display** - This screen displays system information such as track time, current input, track number, and rewinding.
4. **Remote Control Infrared Receiver** - This lens receives signals from the remote control.
5. **Mic/Line Master Level Control** - Use this knob to increase or decrease the master volume of the Mic/Line channels.
6. **Music Master Level Control** - This control adjusts the levels for all Mic/Line channels at once.
7. **Disc Tray** - Insert discs here for playback.
8. **Disc/USB/SD Recorder Control Buttons** - See page 17 for more details.
9. **Graphic Equalizer** - This GRAPHIC EQ is used to BOOST and/or CUT particular frequencies. Each slide fader processes a particular frequency range indicated by the number below it. Frequencies from 60Hz - 200Hz constitute the very low to low range. Frequencies from 200Hz to 1kHz are the mid-range and frequencies from 1kHz to 16kHz make up the high to very high range. To adjust, slide the fader up to boost the frequency presence and down to cut the frequency presence.
10. **Mic/Line Inputs and Controls** - See page 18 for more details.
11. **USB and SD CARD ports** - Plug a USB jumpdrive for playback or an SD card for playback or recording. (See Basic Operations for more information)
12. **Front Panel AV Input** - Use this input to attach an external player to the CHAMPION-REC.
13. **1/8" Mp3 Player/Laptop Input** - Use this jack to attach a Mp3 player, laptop or other media device with a 1/8" connector.
14. **1/4" Headphone Jack** - Use this jack to attach headphones to the CHAMPION-REC. Note: Plugging in headphones will switch off the on-board speakers.
15. **DSP Effects** - See page 19 for more details.
16. **Graphic EQ ON/OFF Switch** - Use the switch to enable/disable the Graphic EQ.
17. **Input Selector Buttons** - Use these buttons to select the music input/source. Press AV1 to select the RCA input on the front panel, and AV2 to select the RCA input on the back panel. Press AV3 to toggle between the second RCA input on the rear panel and the 1/8" input on the front panel. Press DVD to toggle between the disc player, USB jumpdrive reader and SD card reader.
18. **Power Switch** - Use this button to power the CHAMPION-REC on and off.

# Descriptions and Functions cont.

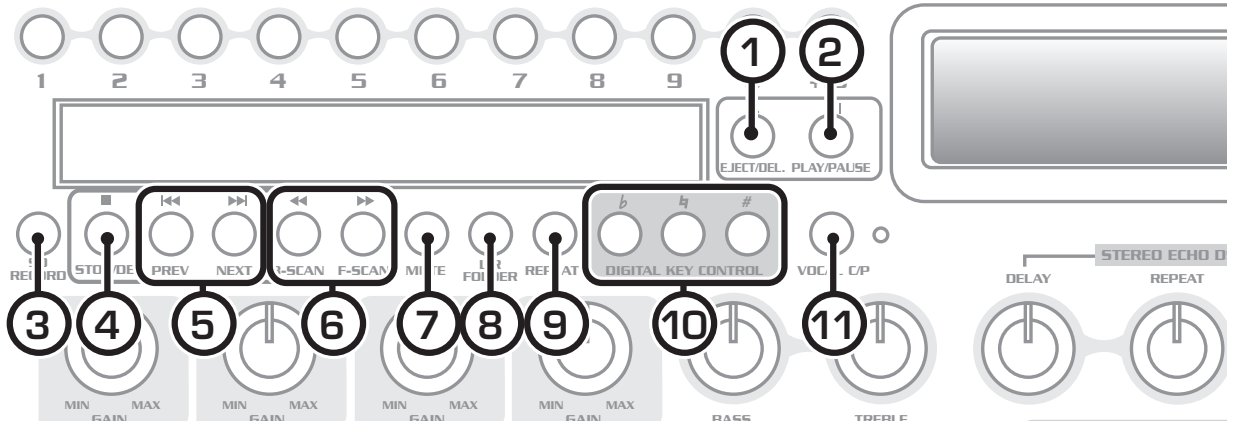

## Disc Player Control Buttons

- 1. Eject/Delete Button** - In disc mode, this button is used to open and close the disc tray. In SD playback mode, press this button simultaneously with the 'Stop/Del' Button to delete a file from the SD card (see SD Recording in the Operations section).
- 2. Play/Pause Button** - Press this button to play a track that is stopped or paused, and pause a track that is playing.
- 3. SD Record Button** - Use this button to enter record mode, and to start and stop a recording (see SD Recording in the Basic Operations section).
- 4. Stop/Delete Button** - Use this button to stop playback. In SD playback mode, press this button simultaneously with the 'Eject/Del Button' to delete a file from the SD card (see SD Recording in the Basic Operations section).
- 5. Prev/Next** - Press Prev to jump to the previous track, and Next to jump to the next track.
- 6. B-Scan/F-Scan** - Press B-scan to scan backwards through the current track, and F-scan to scan forward through the current track.
- 7. Mute Button** - This button will silence the audio from the playback source, but not the microphone audio.
- 8. L/R Folder Button** - This button toggles between left channel, right channel and stereo outputs. Selecting L will place the left channel on the left and right channel outputs, and selecting R will place the right channel on the left and right channel outputs. \* \* \*
- 9. Repeat** - This button will cycle through the available repeat options for the current audio media.
- 10. Digital Key Control** - These buttons adjust the key of the disc audio.
  - b** (flat): will lower the key of the music.
  - ♮** (natural): will return the key to normal.
  - #** (sharp): will raise the key of the music.
- 11. Vocal Cancel/Partner** - This button will remove the vocal track from multiplexed discs. The Vocal Cancel Feature removes vocals from multiplex formatted discs. Press the button one time to enable this function. When Vocal Cancel is enabled, the LED will be lit. The Vocal Partner Feature temporarily removes vocals from multiplex formatted discs only when singing into a connected microphone. When the singing stops, the vocal track is automatically resumed. Press the button two times to enable this function. When Vocal Partner is enabled, the LED will be blinking.

# Descriptions and Functions cont.

VOCAL

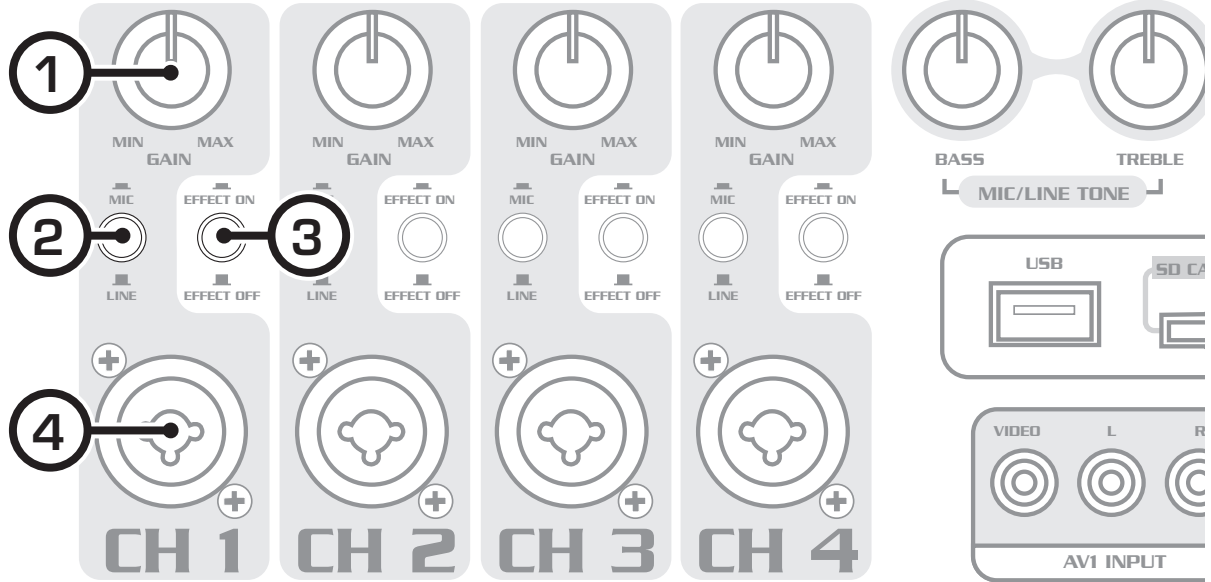

## Channel Controls

1. **Gain Control** - This dial controls the volume on this mic/line channel. Turn the dial clockwise to increase the volume, and counter-clockwise to decrease.
2. **Mic/Line Button** - Use this button to switch between high and low level devices. When using a microphone, guitar or keyboard use the MIC setting to boost the signal. When attaching a self amplifying device like an amplifying mixer or player, set the button to LINE.
3. **Effect On/Effect Off Button** - Press this button in to apply the DSP effects to this channel. Press the button again to turn off the effects on this channel. The effects that are applied to these channels are controlled using the DSP EFFECT controls, and MIC/LINE TONE controls.
4. **XLR/1/4" Combo Jack** - Use this combination jack to plug in a microphone or instrument using a 1/4" jack or an XLR jack.  
 NOTE: Plugging a cable into a channel that is being used by a wireless mic will switch off that wireless mic. If you want to use the wireless mics and wired mics or instruments, make sure you plug the cables into unused channels. The wireless mic module in the top expansion slot uses channel 1 and 2. The bottom expansion slot uses channel 3 and 4.



# Descriptions and Functions cont.

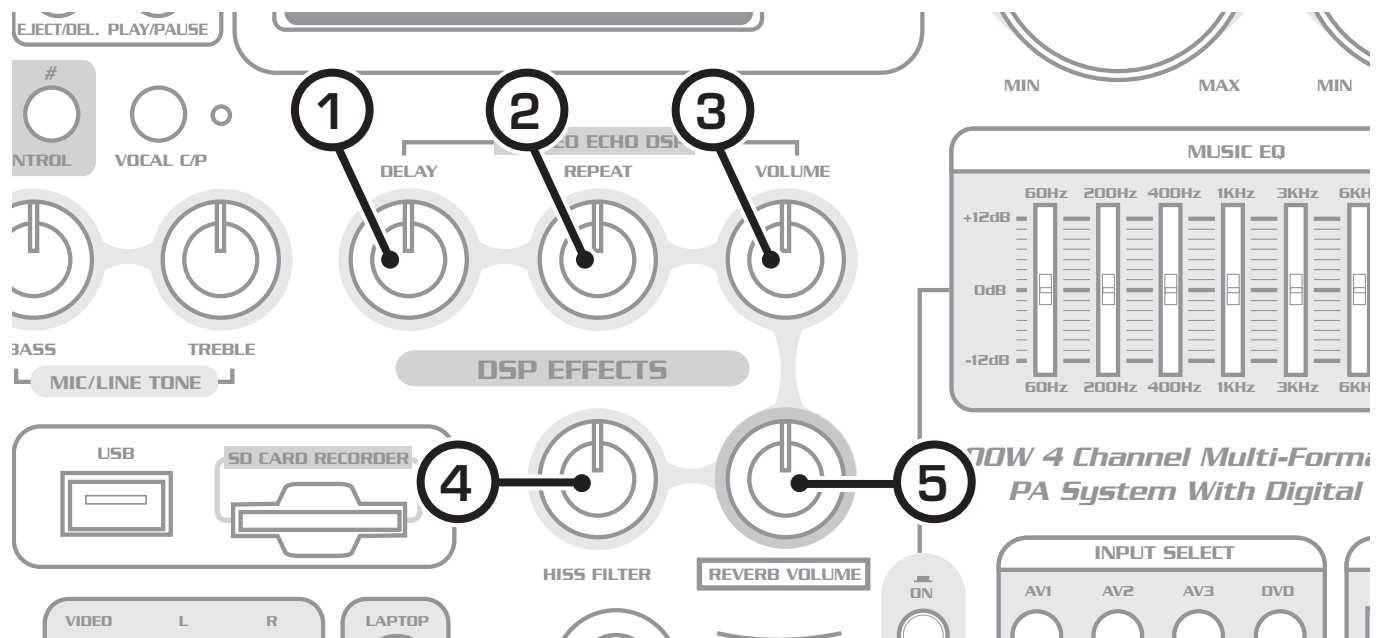

## DSP Effects

- 1. Echo Delay Control** - This dial controls the amount of time between the echo repetitions. Turn this dial clockwise to increase the delay, and counter-clockwise to decrease.
- 2. Echo Repeat Control** - This dial controls the amount of repetitions in the echo. Turn this dial clockwise to increase the amount of echos, and counter-clockwise to decrease.
- 3. Echo Volume Control** - This dial controls the volume of the echo effect. Turn this dial clockwise to increase the volume of the echos, and counter-clockwise to decrease.
- 4. Hiss Filter** - This dial controls the amount of hiss filter that is applied to the mic/line channels.
- 5. Reverb Volume Control** - This dial controls the volume of the reverb effect. Turn this dial clockwise to increase the volume of the reverb effect, and counter-clockwise to decrease.

# Descriptions and Functions cont.

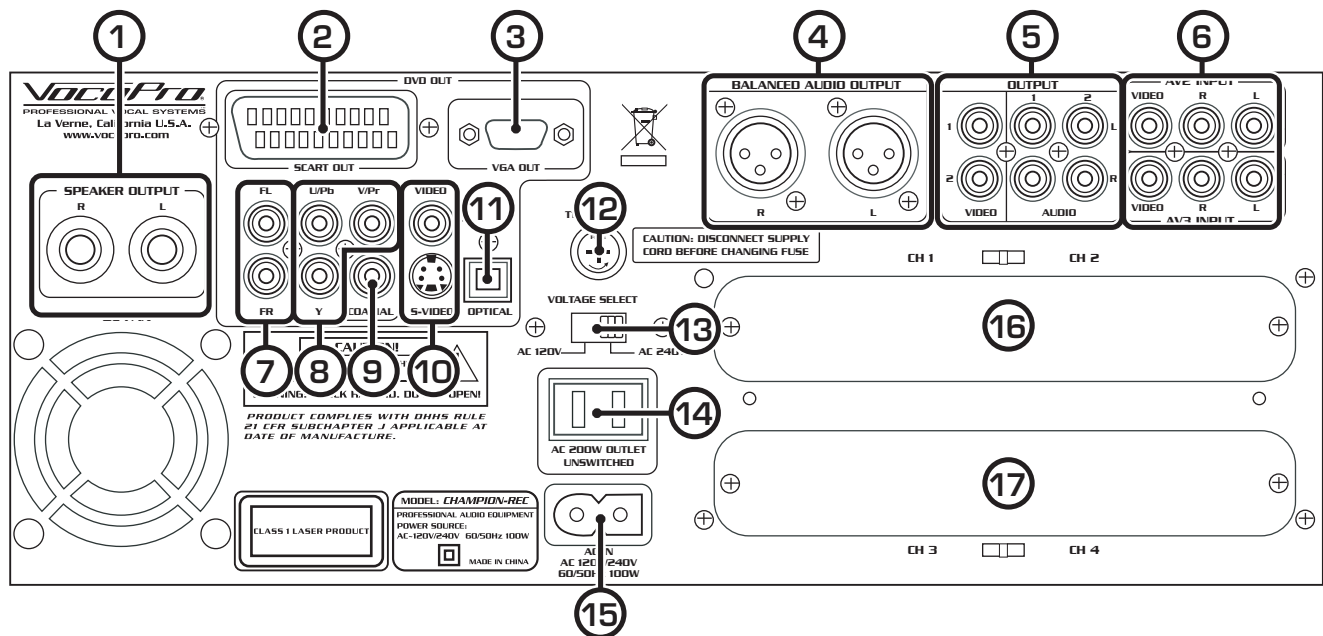

## Rear Panel

1. **¼" L/R Speaker Outputs** - Attach the CHAMPION-REC speakers here using the included ¼" to ¼" cables.
2. **SCART Output** - Use this output to connect to European TV systems that utilize SCART inputs.
3. **VGA Output** - Use this output to connect to TVs or monitors that utilize VGA inputs.
4. **L/R XLR Balanced Audio Output** - Use these outputs to connect the CHAMPION-REC to an external system, such as an in-house system at a club.
5. **RCA A/V Outputs** - Use this output to connect to additional TVs, monitors, recorders, or other devices.
6. **RCA A/V Inputs** - Use this input to connect an external player.
7. **FL/FR Audio Output** - Left and Right stereo audio output. Note that microphone audio will not be present on this output. The graphic EQ does not adjust this output.
8. **Component (Y/Pb/Pr) Video Output** - Use this output to connect to a TV or monitor with Component (Y/Pb/Pr) inputs.
9. **Coaxial Digital Audio Output** - Use this audio output to connect to a digital receiver. Note that microphone audio will not be present on this output. The graphic EQ does not adjust this output.
10. **RCA and S-Video Video Outputs** - Use these video outputs to connect to a TV or monitor that has RCA inputs or S-Video inputs.
11. **Optical Digital Audio Output** - Use this audio output to connect to a digital receiver. Note that microphone audio will not be present on this output. The graphic EQ does not adjust this output.
12. **Fuse Cover** - Remove to access the fuse. Note: Replace only with type listed on back panel.
13. **Volatage Selector Switch** - Use this to select the voltage. 120V for United States, 240V for Europe.
14. **Power Output** - Use this output to power another device up to 200W.
15. **AC Power Input** - Connect the power cable here.
16. **CH1/2 Wireless Microphone Module Port** - Receives signal from wireless microphones. Use the dials to adjust the volume of the wireless microphone audio. Houses the wireless module for channels 12. \*\*Available only on CHAMPION-REC 3, 4, 5, & 6 Models\*\* (See Basic Operations for more information)
17. **CH3/4 Optional Wireless Microphone Module Port** - Use this port to install the channel 3-4 optional wireless microphone module (sold separately). Houses the wireless module for channels 3-4. \*\*Available only on CHAMPION-REC 3, 4, 5, & 6\*\* (See Basic Operations for more information)

# Descriptions and Functions cont.

## Remote Control

1. **Mute Button** - This button will silence the audio from the playback source, but not the microphone audio.
2. **Eject Button** - Use this button to open/close the disc tray.
3. **Input Select Buttons** - Use these buttons to select the music input/source. Press AV1 to select the RCA input on the front panel, and AV2 to select the first RCA input on the back panel. Press AV3 to toggle between the second RCA input on the back panel and the 1/8" input on the front panel. Press DVD to toggle between the disc player, USB jumpdrive reader and SD card reader.
4. **Mic/Line Master Volume Buttons** - Use this button to adjust the master volume of the mic/line inputs.
5. **Program Button** - Use this button to enter program mode. (See basic Operations for more information)
6. **Enter Button** - Use this button to activate a selected menu item in an on-screen menu.
7. **Menu Button** - Use this button to access a disc menu.
8. **Play/Pause Button** - Plays a paused or stopped track, and pauses a playing track.
9. **B-Scan/F-Scan Buttons** - In playback mode, press B-scan to scan backwards through the current track, and F-scan to scan forward through the current track.
10. **Number Buttons** - In playback mode use these buttons to jump directly to a track for playback.
11. **Audio Button** - Will switch between alternate audio tracks on a DVD. Note: Not all DVDs have alternate audio tracks available.
12. **Angle Button** - Use this button to select viewing angles on a DVD. Note: Not all DVDs have alternate viewing angles available.
13. **Slow Button** - Use this button to view DVD video in slow motion.
14. **Digital Key Control Button** - These buttons adjust the key of the disc audio.  
*b* (flat): will lower the key of the music.  
*#* (sharp): will raise the key of the music.
15. **Record** - Use this button to record to SD card. Press once to put the Champion-REC in record mode. Press again to begin recording once the "REC" indicator starts blinking slowly. Press again to finish recording. See the recording section for more details.
16. **Music Master Volume Buttons** - Use this button to increase/decrease the master volume.
17. **Setup Button** - Use this button to access the CHAMPION-REC setup menu.
18. **Arrow Buttons** - Use these buttons to navigate on-screen menus.

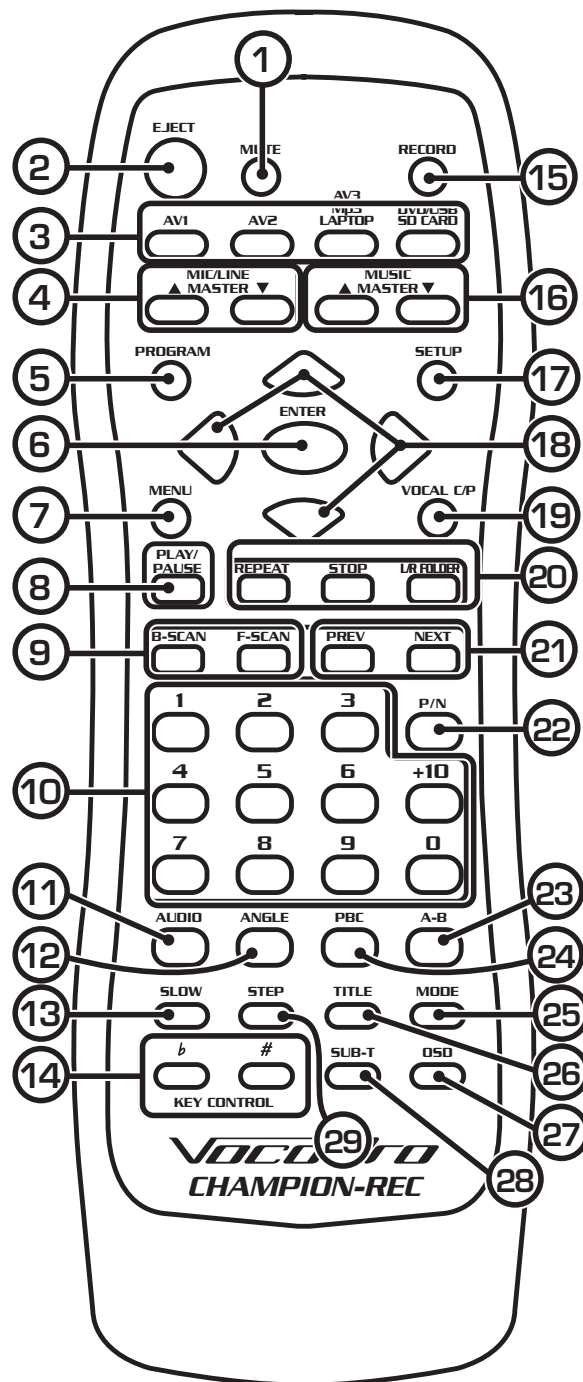

# Descriptions and Functions cont.

- 19. Vocal Cancel/Partner Button** - This button will remove the vocal track from multiplexed discs.
- 20. Multi-Function Buttons:**  
**REPEAT** - This button will cycle through the available repeat options for the current audio media.  
**STOP** - This button will stop a track that is playing.  
**L/R Folder** - This button toggles between left channel, right channel and stereo outputs. Selecting L will place the left channel on the left and right channel outputs, and selecting R will place the right channel on the left and right channel outputs.
- 21. Prev/Next Buttons** - Press Prev to jump to the previous track, and Next to jump to the next track.
- 22. P/N Button** - Use this button to switch between PAL and NTSC. Use NTSC for United States and PAL for Europe.
- 23. A-B Button** - Use this button to loop a section of a track. Press once to set the start point, again to set the end point, the track will then loop. Press the button again to exit the loop.
- 24. PBC Button** - This button activates menu navigation on VCD Discs.
- 25. Mode Button** - Use this button to change the picture mode.
- 26. Title Button** - Use this button to go to the title screen of a DVD disc.
- 27. OSD Button** - Use this button to show/hide the on-screen display, and cycle through the time display modes.
- 28. Subtitle Button** - Use this button to switch between available subtitles on a DVD. Note: Not all DVDs have subtitles available.
- 29. Step Button** - Use this button to advance forward one frame at a time on a DVD.

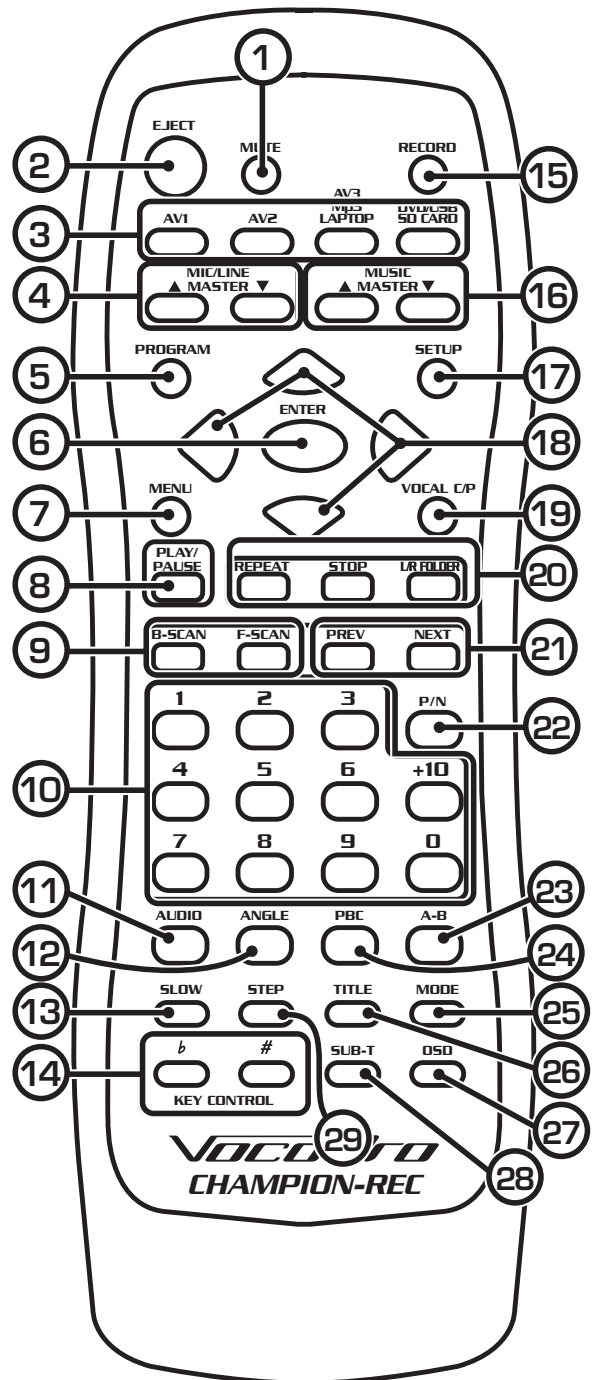

# Basic Operations

## SD Recording

You can record music and microphones/instruments to SD card. SD recording is quick, efficient, and sounds great. Follow the steps below to get started.

1. Insert SD card into the SD card slot as shown.

Note: Make sure the SD card's lock tab is NOT set to lock. This will prevent files from being recorded to the SD card.

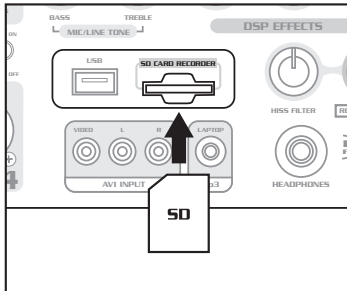

2. Press the SD RECORD button

This will place the unit into 'record standby mode' indicated by the REC icon blinking in the bottom right on the display. There are two blink speeds for the REC icon:

Fast blink: The SD card is being prepared for recording

Slow blink: The SD recorder is ready to record

NOTE: Larger capacity SD cards take longer to prepare for recording

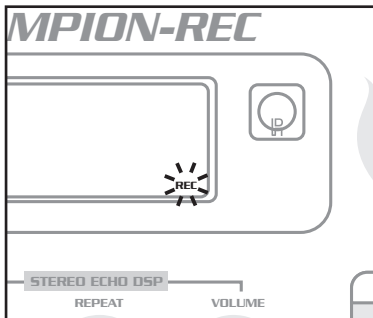

3. Use the INPUT SELECT buttons to select your music source. If you are just recording a microphone or instrument signal (with no music) select SD card as the source.

4. Adjust microphone, instrument and/or music levels to achieve an ideal mix.

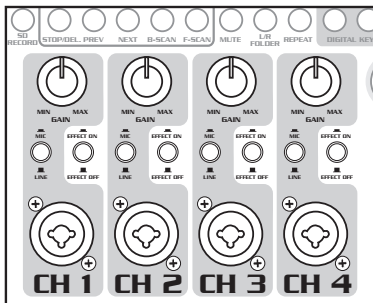

# Basic Operations

5. Once the channels are mixed, use the master level controls to increase or decrease the overall recording level.

Note: If you are doing late night recording or find that the speaker output is too loud while recording, you can connect headphones to mute the speaker output.

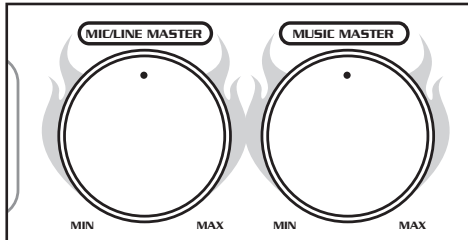

6. Press the SD RECORD button to start recording.

NOTE: During recording, the REC icon will be display solid.

7. Press SD RECORD to stop the recording and create a file on the SD card.

The recordings are stored on the SD card in the following folder:

ROOT/REC/LINE\_IN. The files are .mp3 format 128kbps.

## SD Card Playback

1. Insert SD card into the SD card slot as shown. When you insert an SD card with multiple folders, playback will start from the first file in the first folder and continue to play back all files in all folders. If you want to play a file from another folder, use the FOLDER button (below).

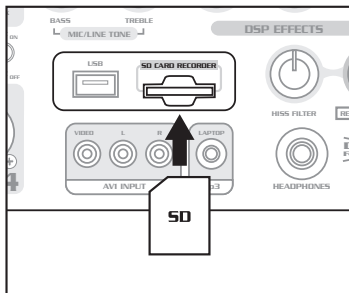

NOTE: SD playback will automatically begin. **Make sure the SD card's lock tab is not set to lock.** This will prevent playback from the SD card.

2. Use the same playback controls (PREV/NEXT/STOP/PAUSE/etc) used to control disc playback to control SD card playback.

## Switching Folders on the SD Card

It is not recommended to insert SD cards with nested folders (folder inside a folder). The only nested folder on the SD card should be the folder used for recording (automatically created by the SD recorder).

To switch folders:

1. Press the FOLDER button to enter FOLDER mode. You will see the FOLDER icon appear in the display

NOTE: In folder mode, the PREV/NEXT buttons are used to navigate folders, not tracks.

2. Use the PREV/NEXT buttons to navigate the folders on the card.

3. Press FOLDER again to exit FOLDER mode.

## Deleting a File

1. In SD card mode go to the file you want to delete by first playing it.

2. Simultaneously press the Stop/Del. and Eject/Del. buttons to delete the file.

3. DEL will momentarily appear in the display. When it disappears the deletion is complete.

NOTE: Make sure your SD card lock tab is not set to LOCK.

# Basic Operations

## Using the Disc Player

To play a disc:

1. Use the Input select buttons to select the DVD player.
2. Press eject to open the disc tray.
3. Place one disc in the tray, label side up.
4. Press eject again to close the tray. Do not try to manually force the tray closed.
5. The disc will automatically begin to play. (Disc will not automatically begin to play if autoplay is turned off. See the setup menu section for more details.)

## Selecting the Input Source

To select the input source, use the input select buttons on the front panel or remote control.

- AV1: The RCA input on the front panel.
- AV2: The first RCA input on the rear panel.
- AV3 - Mp3/LAPTOP: Switches between the 1/8" jack on the front panel and the second RCA input of the rear panel.
- DVD - USB - SD CARD: Switches between the internal disc player, USB and SD card reader.

## Playing from USB Jumpdrive or SD Card

To play songs, videos and other files from a USB jumpdrive or SD card:

1. Plug a USB jumpdrive or SD card into the reader slots on the front panel of the CHAMPION-REC.
2. Use the input select buttons to switch to either the USB or SD port.
3. The first readable file on the card or drive will begin to play automatically. (File will not automatically begin to play if autoplay is turned off. See the setup menu section for more details.)

## Using DSP Effects

The DSP effects can add a stylized feel to vocals and instruments. The DSP Effects include: Delay, Repeat, Hiss Filter and Reverb. To use DSP effects:

1. Connect a microphone or instrument to one of the input channels on the front panel.
2. Press in the effects button on that channel to enable effects for that channel.
3. Adjust the DSP effects dials while speaking into the microphone until you are satisfied with the sound.

Note: Although MIC/LINE TONE treble and bass are not DSP Effects, they will be enabled/disabled by the EFFECT ON/OFF buttons.

## Using Digital Key Control

If a song's natural musical key is either too high, or too low to be sung comfortably, use the DIGITAL KEY CONTROL feature to bring the musical key into range.

- Press the **#** (sharp) button to raise the key
- Press the **b** (flat) button to lower the key
- Press the **4** (natural) button to return the key to its natural position

There is a maximum of 6 steps in either direction (UP/DOWN.) The current setting is displayed in the on-screen display when the key is changed.

## Programming a Custom track order

A custom track order can contain up to 16 tracks. To program a custom track order:

1. Insert a disc in the disc player.
2. Press the program button on the remote control to enter the program menu.
3. Use the arrow keys to highlight the first open track slot.
4. Use the number keys to enter the number of the track.
5. Repeat steps 3 and 4 until the desired track order is complete.
6. Use the arrow buttons to highlight "PLAY" in the menu, and press enter to begin playback, or press play on the remote control.

To exit the programmed track order playback, press stop on the remote control or front panel.

## Using the File Navigation Menu

The file navigation menu will be displayed when a USB drive, SD card, or disc containing files is selected for playback. Use the arrow keys to navigate the menu. To play a track or file, highlight the track or file, then press enter on the remote control.

# Basic Operations

## Using the Optional Wireless Microphones

To use the wireless mics:

1. Attach the included antennas to the wireless mic module.
2. Insert a battery into the mic.
3. Switch the mic ON.
4. When the mic is ON, the RF light on the rear panel will turn on.
5. Use the volume control on the rear panel module, the channel volume control, and the master mic volume control to adjust the volume the desired level.
6. Repeat these steps for additional mics.

## Removing an Optional Wireless Module

The Wireless modules are designed to be easily removed and installed in case it requires service.

To remove a wireless module:

1. **Turn the CHAMPION-REC OFF, and unplug the power cable.**
2. Remove the two screws that hold the module in place.
3. Carefully slide the module out.
4. Carefully detach the connector cable.  
**NOTE:** Make sure the cable does not fall back into the unit. It may be necessary to temporarily secure the cable to the unit with tape while there is no module in the slot.

## Installing an Optional Wireless Module

The Wireless modules are designed to be easily removed and installed in case it requires service.

To install a wireless module:

1. **Turn the CHAMPION-REC OFF, and unplug the power cable.**
2. (If the slot cover is already removed, skip to step 4)  
Remove the two screws that hold the slot cover in place.
3. Carefully detach the connector cable from the slot cover.  
**NOTE:** Make sure the cable does not fall back into the unit. It may be necessary to temporarily secure the cable to the unit with tape while there is no module in the slot.
4. Carefully connect the connector cable to the module. The cable plug is designed to fit only one way, if it does not fit correctly, flip the plug over and try again.
5. Carefully slide the module into the slot.
6. Secure the module with the two screws.



# Setup Menu

## Setup Menu

Press the setup button on the remote control to enter the setup menu. Press the setup button on the remote control while in the setup menu to exit.

## System Setup

### TV System: NTSC, PAL60, PAL, AUTO

NTSC: Use this setting for North America.

PAL60: Use this setting for regions that use PAL at 60Hz.

PAL: Use this setting for Europe.

AUTO: The unit will attempt to auto detect the video system.

### Auto Play: ON, OFF

On: Will play a disc as soon as it is put in.

Off: Will wait for the play button to be pushed before playing a disc.

### Video: INTERLACE-YUV, TV-RGB, P-SCAN YPBPR, PC-VGA, S-VIDEO

Use these settings to change the video output of the Component (Y/Pb/Pr) outputs.

### TV Type: 4:3PS, 4:3LB, 16:9

4:3PS: Use this setting for viewing a standard movie on a standard TV.

4:3LB: Use this setting for viewing a widescreen movie on a standard TV.

16:9: Use this setting for a widescreen TV.

### Password: - - - -

Use this setting to lock/unlock the ratings. The default password is 0000. To set the password, first unlock the password, then enter a new password and press enter.

### Rating: G, PG, PG13, R, NC-17

This setting controls what rating of DVD movie can be watched on the CHAMPION-REC. To change this setting, the password must be set to unlocked.

### Default: RESTORE

Restore: Will return all settings to factory default.

### Resume: ON, OFF

On: Will continue playback from the last point when the unit was turned off.

Off: Will playback from the beginning of the disc when the unit is turned back on.

## Language Setup

### OSD Language: English, Chinese, German, Spanish, French, Portuguese

Select what language will appear on the on-screen display.

### Audio Language: Chinese, English, Japanese, French, Spanish, Portuguese, Latin, German

Select a preferred audio language for DVDs. Note that not all DVDs have every language available.

### Subtitle Language: Chinese, English, Japanese, French, Spanish, Portuguese, German, Off

Select a language for the DVD subtitles. Note that not all DVDs have multiple languages available.

### Menu Language: Chinese, English, Japanese, French, Spanish, Portuguese, German, Latin

Select a language for the DVD menu. Note that not all DVDs have multiple languages available.

# Setup Menu

## Audio Setup

**Audio Out:** SPDIF/OFF, SPDIF/RAW, SPDIF/PCM

SPDIF/OFF: Select to disable SPDIF output.

SPDIF/RAW: Select when connecting to a 5.1 channel digital amplifier (DTS/Dolby Movie.).

SPDIF/PCM: Select when connecting to a 2-channel digital amplifier (Audio CD.).

**Key:** -6 to +6

This menu item functions the same as the Digital Key Control buttons on the front panel and remote control.

## Video Setup

**Brightness:**

Set the brightness of the image with this setting. A lower value will make the image darker.

**Contrast:**

Set the contrast of the image with this setting. A higher value will make the light colors lighter and the dark colors darker. A lower value will make the light and dark colors less vibrant.

**Hue:**

Set the hue or color of the image with this setting.

**Saturation:**

Set the Saturation of the image with this setting. Saturation makes the colors in an image more intense.

**Sharpness:**

Set the sharpness of the image with this setting.

## Speaker Setup

**Downmix:** LT/RT, STEREO, VSS

LT/RT: Select when connecting to a Dolby Digital amplifier.

STEREO: Select when connecting to a 2-channel stereo amplifier/mixer .

VSS: Virtual surround sound. Select when using the 5.1 channel outputs on the rear panel.

## Digital Setup

**OP MODE:** LINE OUT, RF REMOD

LINE OUT: This sets the output level to normal.

RF REMOD: This will slightly increase the output level.

**Dynamic Range:** FULL, 6/8, 4/8, 2/8, OFF

Use this control to adjust the dynamic range.

**Dual Mono:** STEREO, MONO L, MONO R, MIX MONO

Stereo: Select for standard L/R audio output.

Mono L: Select for mono audio output with the left channel on both sides.

Mono R: Select for mono audio output with the right channel on both sides.

Mix mono: Select for mono audio output to both sides.

# Troubleshooting

## **The disc tray will not open.**

Make sure the CHAMPION-REC is powered on.  
Make sure the input select is set to DVD.

## **A disc is playing, but no sound is coming from the speakers.**

Make sure the music master volume is turned up.  
Make sure the speaker cables are connected firmly.  
If you are playing a VOB file from an SD card or jumpdrive, it may not function as VOB file playback is not supported.

## **The disc player will not play a particular disc.**

Make sure the input select is set to DVD.  
Make sure the disc is not scratched or dirty.  
Some types of recorded discs may not be compatible with the CHAMPION-REC.

## **The Graphic EQ has no effect on the music.**

Make sure the EQ ON/OFF button is set to ON.

## **Microphone audio is not present in the speakers.**

Make sure the mic is switched on.  
Make sure the MIC/LINE button on the mic channel is set to MIC.  
Make sure the mic channel and master mic volume are turned up.

## **An instrument such as a guitar or keyboard that is plugged into the MIC/LINE channels cannot be heard via speakers.**

Make sure the MIC/LINE button on the input channel is set to MIC.  
Make sure the channel and master mic volume are turned up.

## **No microphone audio is present in the FR/FL, or digital audio outputs.**

This is not a malfunction. Microphone audio is not output through these channels.

## **No Wireless microphone audio is present.**

Make sure the wireless mics are switched on.  
Make sure the volume is turned up on the wireless mic module.  
Make sure the mic channel and mic master volume are turned up.  
Make sure the microphone battery is charged and installed correctly.  
If there is a wired mic or instrument plugged into the same channel as the wireless mic, it will switch off the wireless mic, make sure that cables are only plugged into unused channels.

## **A USB Jumpdrive or SD card is not playing.**

Make sure the input selector is set to USB or SD.  
Make sure the card or drive is formatted with FAT or FAT32. NTFS format cannot be read by the CHAMPION-REC.  
If you are playing a VOB file from an SD card or jumpdrive, it may not function as VOB file playback is not supported.  
Make sure the SD card lock tab is not set to LOCK.

## **The remote control is not working.**

Make sure the CHAMPION-REC is powered on.  
Make sure you are within 23 feet of the CHAMPION-REC.  
Make sure the remote control batteries are not dead.

## **Cannot record to SD card.**

Make sure the SD card lock tab is not set to LOCK.  
Make sure you have sufficient space on the SD card to record  
Make sure the SD card is ready for recording (indicated by a slow blinking REC icon)

## **Recording level is too low.**

Increase the channel gain controls  
Increase the master music and/or master mic levels

## **No Video**

This unit will not display VGA video output from DVDs with copy protection. This is not a manufacturing defect. It is due to the anti-piracy coding used to protect the DVD from VGA video copying. If you use VGA for video output, please check the DVD packaging to make sure it is not copy-protected prior to viewing.

# **VocoPro**<sup>®</sup>

---

**PROFESSIONAL VOCAL SYSTEMS**<sup>™</sup>



CHAMPION-REC Owner's Manual  
© VocoPro 2012  
v1.0326  
[www.vocopro.com](http://www.vocopro.com)