

# DA-3700 PRO

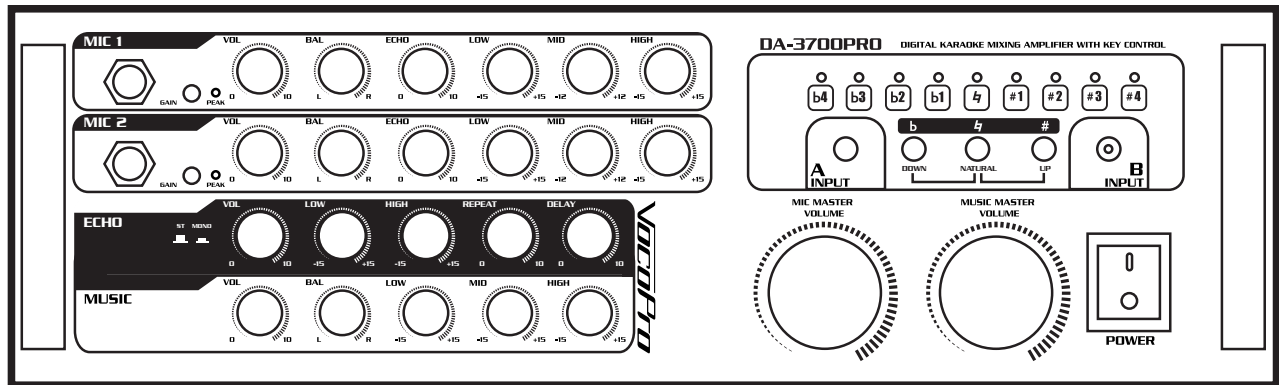

## Digital Karaoke Mixing Amplifier with Key Control

OWNER'S MANUAL

# Table of contents

## Introduction

Safety Instructions .....	1
FCC Information .....	2
Welcome .....	3
Listening for a Lifetime .....	4
Specifications and Features .....	5

## Getting Connected

CD/DVD player connection .....	6
TV/Display device connection .....	6
Amplifier, mixer and external sound system connections .....	7
External speaker connection .....	7
Mic(s) connection .....	8
Effects Loop connections	
Music .....	8
Vocal .....	8

## Controls and Functions

Front Panel .....	9
Rear Panel .....	11
Remote Control .....	12

## Basic and Advanced Operations .....

## Troubleshooting .....

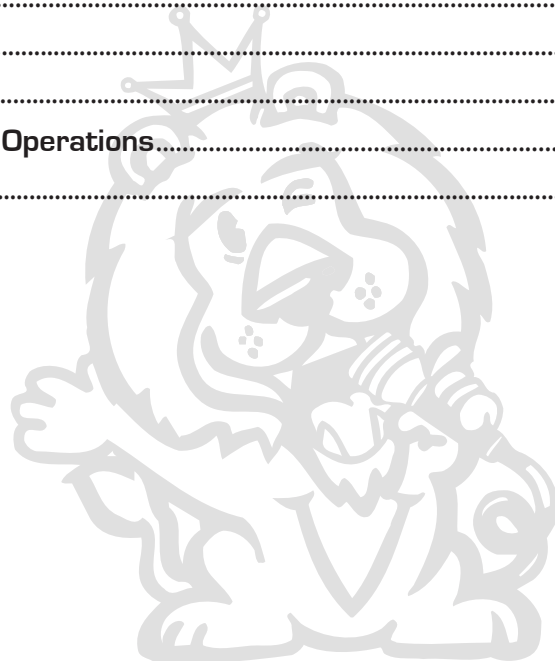

**VocoPro**

ULTIMATE CHOICE OF KARAOKE ENTERTAINMENT

# Safety Instructions



**CAUTION**  
RISK OF SHOCK



CAUTION: To reduce the risk of electric shock, do not remove cover (or back). No user-serviceable parts inside. Only refer servicing to qualified service personnel.

## Explanation of Graphical Symbols



The lightning flash & arrowhead symbol, within an equilateral triangle, is intended to alert you to the presence of danger.



The exclamation point within an equilateral triangle is intended to alert you to the presence of important operating and servicing instructions.

### WARNING

To reduce the risk of fire or electric shock, do not expose this unit to rain or moisture.

**1. Read Instructions** - All the safety and operating instructions should be read before the appliance is operated.

**2. Retain Instructions** - The safety and operating instructions should be retained for future reference.

**3. Heed Warnings** - All warnings on the appliance and in the operating instructions should be adhered to.

**4. Follow Instructions** - All operating and use instructions should be followed.

**5. Attachments** - Do not use attachments not recommended by the product manufacturer as they may cause hazards.

**6. Water and Moisture** - Do not use this unit near water. For example, near a bathtub or in a wet basement and the like.

**7. Carts and Stands** - The appliance should be used only with a cart or stand that is recommended by the manufacturer.

**7 A.** An appliance and cart combination should be moved with care. Quick stops, excessive force, and uneven surfaces may cause an overturn.



**8. Ventilation** - The appliance should be situated so its location does not interfere with its proper ventilation. For example, the appliance should not be situated on a bed, sofa, rug, or similar surface that may block the ventilation slots.

**9. Heat** - The appliance should be situated away from heat sources such as radiators, heat registers, stoves, or other appliances (including amplifiers) that produce heat.

**10. Power Sources** - The appliance should be connected to a power supply only of the type described in the operating instructions or as marked on the appliance.

**11. Grounding or Polarization** - Precautions should be taken so that the grounding or polarization means of an appliance is not defeated.

**12. Power-Cord Protection** - Power-supply cords should be routed so that they are not likely to be walked on or pinched by items placed upon or against them, paying particular attention to cords at plugs, convenience receptacles, and the point where they exit from the appliance.

**13. Cleaning** - Unplug this unit from the wall outlet before cleaning. Do not use liquid cleaners or aerosol cleaners. Use a damp cloth for cleaning.

**14. Power lines** - An outdoor antenna should be located away from power lines.

**15. Nonuse Periods** - The power cord of the appliance should be unplugged from the outlet when left unused for a long period of time.

**16. Object and Liquid Entry** - Care should be taken so that objects do not fall and liquids are not spilled into the enclosure through openings.

**17. Damage Requiring Service** - The appliance should be serviced by qualified service personnel when:

- A. The power supply cord or plug has been damaged; or
- B. Objects have fallen into the appliance; or
- C. The appliance has been exposed to rain; or
- D. The appliance does not appear to operate normally or exhibits a marked change in performance; or
- E. The appliance has been dropped, or the enclosure damaged.

**18. Servicing** - The user should not attempt to service the appliance beyond that described in the operating instructions. All other servicing should be referred to qualified service personnel.

### Note:

To CATV system installers (U.S.A.): This reminder is provided to call the CATV system installer's attention to Article 820-40 of the NEC that provides guidelines for proper grounding and, in particular, specifies that the cable ground shall be connected as close to the point of cable entry as practical.

# FCC INFORMATION (U.S.A .)

## 1. IMPORTANT NOTICE: DO NOT MODIFY THIS

**UNIT!:** This product, when installed as indicated in the instructions contained in this manual, meets FCC requirements. Modifications not expressly approved by Vocopro may void your authority, granted by the FCC, to use this product.

**2. IMPORTANT:** When connecting this product to accessories and/or another product use only high quality shielded cables. Cable(s) supplied with this product **MUST** be used. Follow all installation instructions. Failure to follow instructions could void your FCC authorization to use this product in the U.S.A.

**3. NOTE:** This product has been tested and found to comply with the requirements listed in FCC Regulations, Part 15 for Class "B" digital devices. Compliance with these requirements provides a reasonable level of assurances that your use of this product in a residential environment will not result in harmful interference with other electronic devices. This equipment generates/uses radio frequencies and, if not installed and used according to the instructions found in the owner's manual, may cause interference harmful to the operation of other electronic devices. Compliance with FCC regulations does not guarantee that interference will not occur in all installations. If this product is found to be the source of interference, which can be determined by turning the unit "Off" and "On", please try to eliminate the problem by using one of the following measures:

Relocate either this product or the device that is being affected by the interference.

Use power outlets that are on different branch (circuit breaker or fuse) circuits or install AC line filter(s).

In the case of radio or TV interference, relocate/reorient the antenna. If the antenna lead-in is 300-ohm ribbon lead, change the lead-in to coaxial type cable.

If these corrective measures do not produce satisfactory results, please contact your local retailer authorized to distribute Vocopro products. If you can not locate the appropriate retailer, please contact Vocopro, 1728 Curtiss Court, La Verne, CA 91750.

## CAUTION

The apparatus is not disconnected from the AC power source so long as it is connected to the wall outlet, even if the apparatus itself is turned off. To fully insure that the apparatus is indeed fully void of residual power, leave unit disconnected from the AC outlet for at least **fifteen seconds.**

## CAUTION:

### READ THIS BEFORE OPERATING YOUR UNIT

1. To ensure the finest performance, please read this manual carefully. Keep it in a safe place for future reference.
2. Install your unit in a cool, dry, clean place - away from windows, heat sources, and too much vibration, dust, moisture or cold. Avoid sources of hum (transformers, v motors). To prevent fire or electrical shock, do not expose to rain and water.
3. Do not operate the unit upside-down.
4. Never open the cabinet. If a foreign object drops into the set, contact your dealer.
5. Place the unit in a location with adequate air circulation. Do not interfere with its proper ventilation; this will cause the internal temperature to rise and may result in a failure.
6. Do not use force on switches, knobs or cords. When moving the unit, first turn the unit off. Then gently disconnect the power plug and the cords connecting to other equipment. Never pull the cord itself.
7. Do not attempt to clean the unit with chemical solvents: this might damage the finish. Use a clean, dry cloth.
8. Be sure to read the "Troubleshooting" section on common operating errors before concluding that your unit is faulty.
9. This unit consumes a fair amount of power even when the power switch is turned off. We recommend that you unplug the power cord from the wall outlet if the unit is not going to be used for a long time. This will save electricity and help prevent fire hazards. To disconnect the cord, pull it out by grasping the plug. Never pull the cord itself.
10. To prevent lightning damage, pull out the power cord and remove the antenna cable during an electrical storm.
11. The general digital signals may interfere with other equipment such as tuners or receivers. Move the system farther away from such equipment if interference is observed.

## NOTE:

Please check the copyright laws in your country before recording from records, compact discs, radio, etc. Recording of copyrighted material may infringe copyright laws.

## Voltage Selector (General Model Only)

Be sure to position the voltage selector to match the voltage of your local power lines before installing the unit.

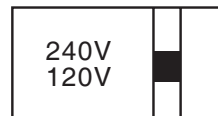



Welcome....



And Thank you for purchasing the **DA-3700 PRO** from VocoPro, your ultimate choice in Karaoke entertainment! With years of experience in the music entertainment business, VocoPro is a leading manufacturer of Karaoke equipment, and has been providing patrons of bars, churches, schools, clubs and individual consumers the opportunity to sound like a star with full-scale club models, in-home systems and mobile units. All our products offer solid performance and sound reliability, and to further strengthen our commitment to customer satisfaction, we have customer service and technical support professionals ready to assist you with your needs. We have provided some contact information for you below.

### VocoPro

1728 Curtiss Court  
La Verne, CA 91750

**Toll Free: 1 (800) 678-5348**

TEL: (909) 593-8893

FAX: (909) 593-8890

### VocoPro Company Email Directory

**Customer Service & General Information**

info@vocopro.com

**Tech Support**

techsupport@vocopro.com

**Remember Our Website**

Be sure to visit the VocoPro website [www.vocopro.com](http://www.vocopro.com) for the latest information on new products, packages and promos. And while you're there don't forget to check out our Club VocoPro for Karaoke news and events, chat rooms, club directories and even a Service directory!

We look forward to hearing you sound like a PRO, with VocoPro, your ultimate choice in Karaoke entertainment.

### FOR YOUR RECORDS

Please record the model number and serial number below, for easy reference, in case of loss or theft. These numbers are located on the rear panel of the unit. Space is also provided for other relevant information

Model Number \_\_\_\_\_

Serial Number \_\_\_\_\_

Date of Purchase \_\_\_\_\_

Place of Purchase \_\_\_\_\_

# Listening for a lifetime

Selecting fine audio equipment such as the unit you've just purchased is only the start of your musical enjoyment. Now it's time to consider how you can maximize the fun and excitement your equipment offers. VocoPro and the Electronic Industries Association's Consumer Electronics Group want you to get the most out of your equipment by playing it at a safe level. One that lets the sound come through loud and clear without annoying blaring or distortion and, most importantly, without affecting your sensitive hearing.

Sound can be deceiving. Over time your hearing "comfort level" adapts to a higher volume of sound. So what sounds "normal" can actually be loud and harmful to your hearing. Guard against this by setting your equipment at a safe level BEFORE your hearing adapts.

To establish a safe level:

- Start your volume control at a low setting.
- Slowly increase the sound until you can hear it comfortably and clearly, and without distortion.

Once you have established a comfortable sound level

- Set the dial and leave it there.
- Pay attention to the different levels in various recordings.

Taking a minute to do this now will help to prevent hearing damage or loss in the future. After all, we want you listening for a lifetime.

Used wisely, your new sound equipment will provide a lifetime of fun and enjoyment. Since hearing damage from loud noise is often undetectable until it is too late, this manufacturer and the Electronic Industries Association's Consumer Electronics Group recommend you avoid prolonged exposure to excessive noise. This list of sound levels is included for your protection.

## Some common decibel ranges:

Level	Example
30	Quiet library, Soft whispers
40	Living room, Refrigerator, Bedroom away from traffic
50	Light traffic, Normal Conversation
60	Air Conditioner at 20 ft., Sewing machine
70	Vacuum cleaner, Hair dryer, Noisy Restaurant
80	Average city traffic, Garbage disposals, Alarm clock at 2 ft.

## The following noises can be dangerous under constant exposure:

Level	Example
90	Subway, Motorcycle, Truck traffic, Lawn Mower
100	Garbage truck, Chainsaw, Pneumatics drill
120	Rock band concert in front of speakers
140	Gunshot blast, Jet plane
180	Rocket launching pad

-Information courtesy of the Deafness Research Foundation

# Specifications

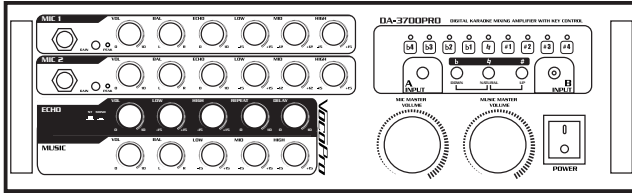

## VocoPro DA-3700 PRO

Digital Karaoke Mixing Amplifier with Key Control

---

Maximum Output	120W + 120W at 4-Ohm 100W + 100W at 8-Ohm
S/N ratio	65dB (mic on) 70dB (mic off)
THD	0.5%
Frequency Response	20Hz--20KHz
Noise Level	<10mV
Tone Balance Control	±12dB
Balance Input	±1.5dB
Split Level	>35dB
Mic Sensitivity	<30mV
Mic Frequency Sound	100Hz ~ 2.5kHz
MIC Tone	
Treble	±10dB
Bass	±10dB
Supply Voltage	110V-220V

---

## Features

- 9-step Digital Key Control
- 2 Unbalanced ¼" Microphone Inputs with -20dB Gain Pad, Volume, Balance, Echo and 3-Way EQ Controls on each Channel
- 2 Switchable RCA A/V Inputs for Source Players (DVD, CD+G, VCD, etc)
- 3 RCA Audio Outputs (Record, Line and Microphone) for Output to Recording Devices, Amplifiers and Mixers
- 2 RCA Video Inputs/Output for Video Connection to a TV or Monitor Device
- Effect Loop for Integration of Outboard Effect Units
- Master Volume, Balance and Low/Mid/High Frequency Controls for input source music
- Master Lo/Hi frequency, Repeat and Delay Echo controls
- Master Microphone volume control
- Remote Key Control input
- 2-Way Binding Post Speaker Outputs
- Remote Control
- 110V/220V Compatible
- Dimensions: 16" (W) x 14" (D) x 5½" (H)

# Getting connected

## CD/DVD player connection

You can simultaneously connect up to two CD/DVD players to the DA-3700 PRO's switchable A/V channels. Using the DA-3700 PRO's remote or front panel, you can easily switch between Channel A and Channel B.

### Audio

Connect the stereo (L/R) RCA cables from the Output of your CD/DVD player to the VCD/CD (INPUT A) or the DVD (INPUT B) L/R inputs on the rear panel of the DA-3700 PRO.

### Video

Connect the video RCA cable from the Video Output of your CD/DVD player to the corresponding VIDEO INPUT on the rear panel of the DA-3700 PRO.

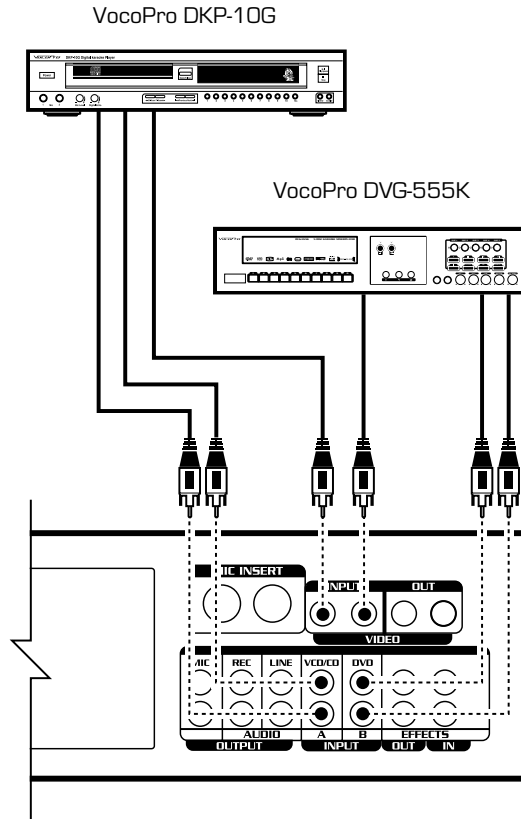

## TV/Display device connection

The DA-3700 PRO has two video inputs and two video outputs. Video inputs A and B correspond to the two input channels. The video that is being input into VIDEO input A will only play when input channel A is active. Likewise, the video that is being input into VIDEO input B can only be viewed if input channel B is active.

Both Video Outputs send the same picture simultaneously to two different TVs or display devices.

Connect the Video RCA cable from the VIDEO output on the DA-3700 PRO to the Video Input on your TV or display device.

NOTE: Switch between Inputs A and B either by using the A/B buttons on the DA-3700 PRO's remote or on the front panel.

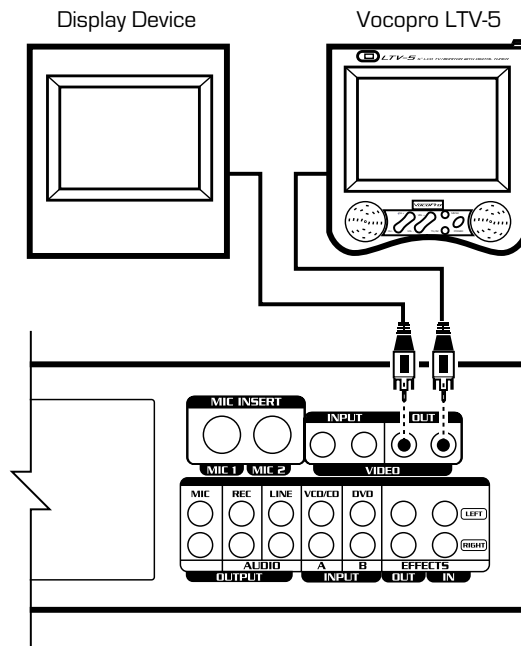



# Getting connected (cont.)

## Amplifier, mixer and external sound system connections

### Music and Vocals

The DA-3700 PRO's LINE OUT (RCA) jacks can be used to connect to a second power amplifier, an external sound system or mixing device. Note: The DA-3700 PRO offers optimum performance when used as an amp for home sound systems and smaller performance systems and speakers. See our VP Series power amplifiers for more professional applications at [VocoPro.com](http://VocoPro.com) or your nearest VocoPro dealer.

Use L/R RCA audio cables to connect to an amplifier, mixer or other external sound system. Connect from the L/R LINE OUTPUT on the DA-3700 PRO to the L/R audio input on your amp, mixer or sound system.

### Outputting Vocals Independently

You can output vocals independently from the DA-3700 PRO into a mixer from the L/R RCA MIC Outputs. Connect the L/R RCA cable from the MIC OUTPUT to an Audio Input on your mixer.

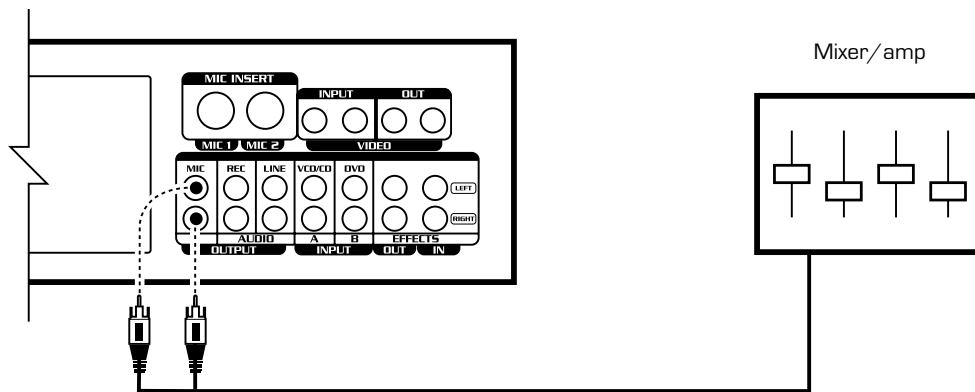

## External speaker connection

You can connect directly to speakers using either MDP (banana plug) speaker cables or standard speaker wires. Be sure to correctly match the polarities (+/-). Connect speakers rated no lower than 4-Ohms to the DA-3700 PRO. Please do not try to connect more than one speaker per channel, as the load may exceed the amplifiers handling capacity, causing it to overload.

If using standard speaker wire, unscrew each plastic bind until you are able to see an interior hole for speaker wire (this is easier to locate when viewing from a side angle). Slide the speaker wires into the slots and tighten the plastic binds to tighten them in place. Be sure there is no insulation on the speaker wire preventing conductivity.

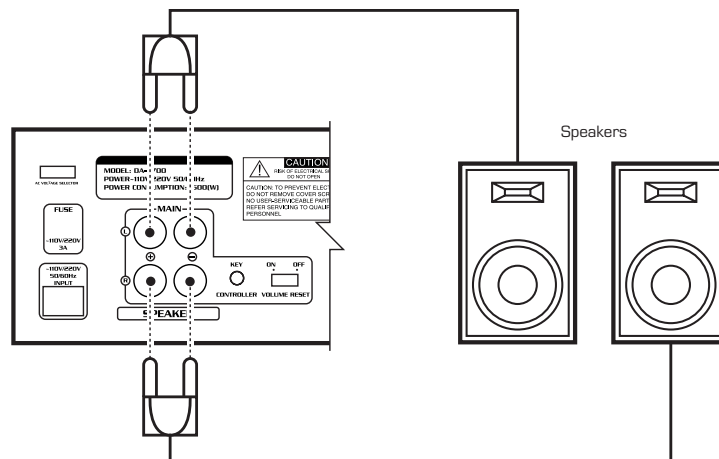

# Getting connected (cont.)

## Mic(s) connection

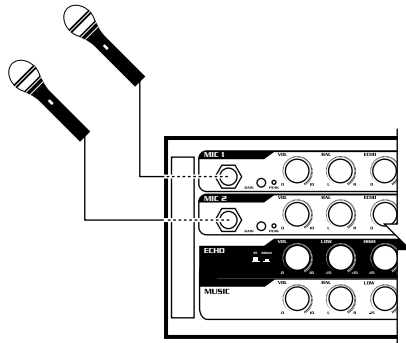

Using a mic cable with a 1/4" end, connect the mic to either of the DA-3700 PRO's microphone inputs.

## A mic with Remote Key Control

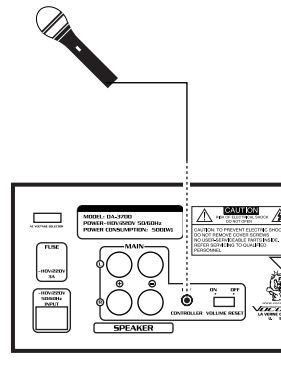

Connect the Remote Key Control cable into the KEY CONTROLLER jack on the rear panel of the DA-3700 PRO.

## Effects Loop connections

### Source Music (Music from a DVD or CD player)

By using the built-in Effects Loop you can add effects such as a professional Digital Key Controller to the source player's music without compromising the quality of the original signal. To use the effects loop connect an RCA cable from the DA-3700 PRO's EFFECTS LOOP L or R OUT jack to the effects unit input. Then connect an RCA cable from the effects unit output, into the DA-3700 PRO's L or R IN jack.

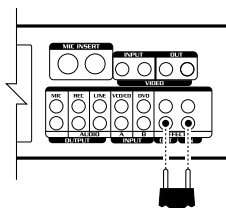
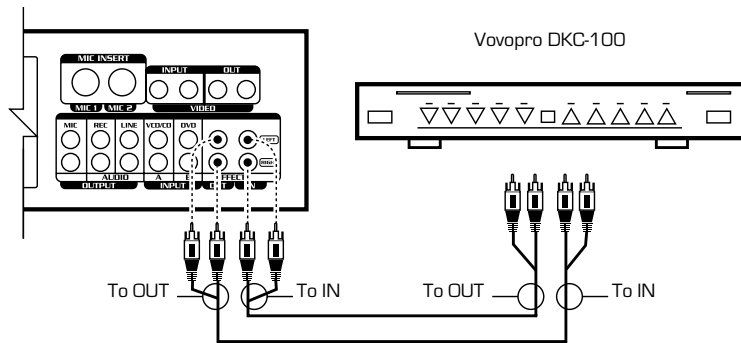

NOTE: If you are not using the Effects Loop, be sure the LOOP BARS are re-connected. Without these, there will be no sound.

### Vocals

The MIC INSERT jacks on the rear panel allow you to loop the vocals through an effects unit. NOTE: In order to do this you must have a 1/4" Y adapter cable (not included) for each microphone line.

Connect the single end of the Y cable into the MIC INSERT jack. Connect one side of the double end into the input on the effects device and the other end into the output of the effects device.

NOTE: If the Y cable is plugged into the DA-3700 PRO but the double ends are not connected to the IN and OUT of a device, there will be no microphone output. So if you are not using effects, be sure the Y cable is unplugged from the DA-3700 PRO.

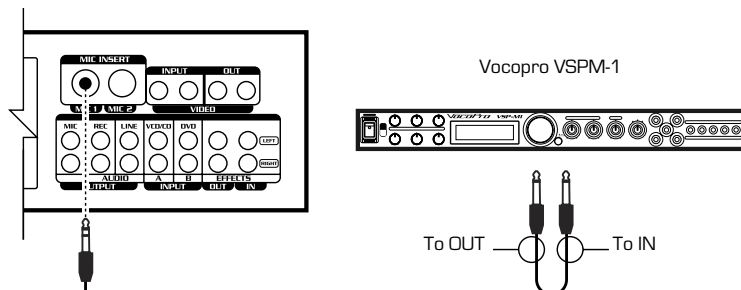

# Front panel description

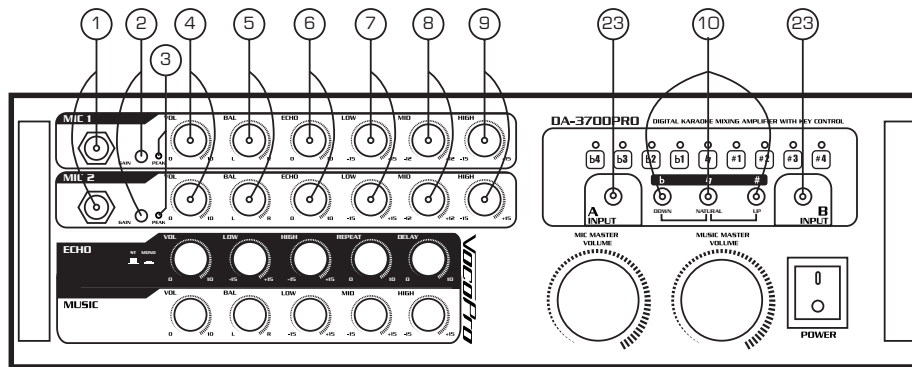

1. MICROPHONE INPUT jacks – Connect your microphones to these inputs with 1/4" cables.
2. -20dB GAIN pads – Press pad to an inward position to decrease the microphone output's gain by -20dB. Release pad to its outer position to have the microphone output revert back to NORMAL volume.
3. PEAK LED indicators – The PEAK LED indicates when the input level is too high.
4. VOL control – This control increases and decreases the VOLUME level for the MIC channels. Turn clockwise to increase MIC VOLUME and counter-clockwise to decrease the MIC VOLUME.
5. BAL control – Use this control to fade the microphone output between the left and right channels. When the balance control is directly centered, equal sound comes out of both the left and right channels giving you perfect stereo sound.
6. ECHO control – This control increases/decreases the amount of ECHO applied to the MIC channels. Turn clockwise to increase ECHO and counter-clockwise to decrease ECHO.
7. LOW control – This control increases/decreases the amount of LOW (bass) frequency response applied to the MIC channels. Turn clockwise to increase the LOW frequency response and counter-clockwise to decrease the LOW frequency response.
8. MID control – This control increases/decreases the amount of MID-RANGE frequency response applied to the MIC channels. Turn clockwise to increase the MID-RANGE frequency response and counter-clockwise to decrease the MID-RANGE frequency response.
9. HIGH control – This control increases/decreases the amount of HIGH (treble) frequency response applied to the MIC channels. Turn clockwise to increase the HIGH frequency response and counter-clockwise to decrease the HIGH frequency response.
10. DIGITAL KEY CONTROL - Use these buttons to raise or lower the musical key of your source music (CD/DVD player). The LEDs indicate where the current key of the music is.
  - b - Lowers the key of the music
  - # - Restores the music back to its original (natural) key
  - # - Raises the key of the music
23. INPUT SELECTOR buttons - Use these buttons to toggle between the two available input channels A and B.

## Front panel description (cont.)

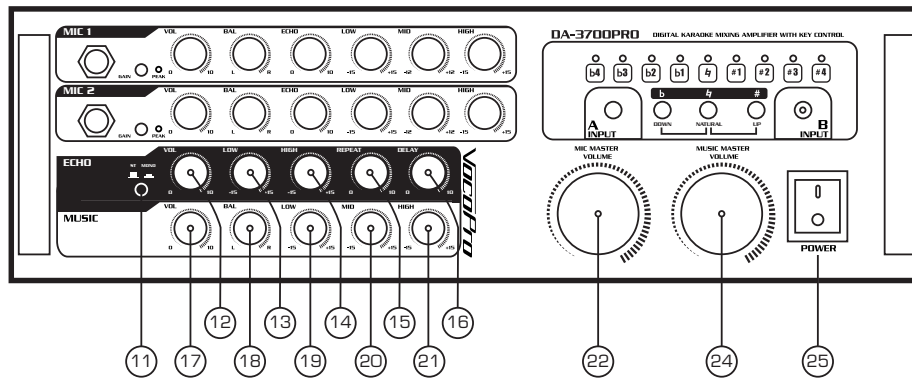

11. ST/MO (Stereo/Mono) - Use this button to switch between the two echo output modes, STEREO and MONO.
12. MASTER ECHO VOLUME control – This control increases/decreases the MASTER VOLUME LEVEL of the ECHO effect available to the MIC 1, 2-3 channels. Turn clockwise to increase MASTER ECHO VOLUME and counter-clockwise to decrease the MASTER ECHO VOLUME.
13. ECHO LO control – This control increases/decreases the amount of LOW frequency response applied during the ECHO effect application. Turn clockwise to increase the LOW frequency response, and counter-clockwise to decrease the LOW frequency response.
14. ECHO HI control – This control increases/decreases the amount of HIGH frequency response applied during the ECHO effect application. Turn clockwise to increase the HIGH frequency response, and counter-clockwise to decrease the HIGH frequency response.
15. ECHO RPT control – REPEAT adjusts the interval repetition of the echo effect. As more REPEAT is applied to the ECHO effect, more echo intervals will occur prior to fading out. Turn clockwise to increase the REPEAT level and counter-clockwise to decrease the REPEAT level.
16. ECHO DEL control – DELAY adjusts the total beginning and ending length of each echo interval. As more DELAY is applied to the ECHO effect, each ECHO interval will become longer in time. Turn clockwise to increase the DELAY level and counter-clockwise to decrease the DELAY level.
17. MUSIC VOL control – This control increases/decreases the MUSIC VOLUME level(s) from INPUT SOURCES that are connected to the CD/DVD channels. Turn clockwise to increase MUSIC VOLUME and counter-clockwise to decrease the MUSIC VOLUME.
18. MUSIC BALANCE control - Use this control to fade the music output between the left and right channels. When the balance control is directly centered, equal sound comes out of both the left and right channels giving you perfect stereo sound.
19. MUSIC LOW control – This control increases/decreases the amount of LOW (bass) frequency response applied to the audio output of INPUT SOURCES connected to the CD/DVD channels. Turn clockwise to increase the LOW frequency response and counter-clockwise to decrease the LOW frequency response.
20. MUSIC MID control – This control increases/decreases the amount of MID-RANGE frequency response applied to the audio output of INPUT SOURCES connected to the CD/DVD channels. Turn clockwise to increase the MID-RANGE frequency response and counter-clockwise to decrease the MID-RANGE frequency response.
21. MUSIC HIGH control – This control increases/decreases the amount of HIGH frequency response applied to the audio output of INPUT SOURCES connected to the CD/DVD channels. Turn clockwise to increase the HIGH frequency response and counter-clockwise to decrease the HIGH frequency response.
22. MIC MASTER VOLUME control - Use this to control the overall volume of both microphone channels. Turn clockwise to increase the master microphone volume and counter-clockwise to decrease the master microphone volume.
24. MUSIC MASTER VOLUME control - Use this to control the overall volume of the music from the CD/DVD player(s) that are connected to the DA-3700 PRO.
25. POWER button – This button turns the DA-3700 PRO ON and OFF.

# Rear panel description

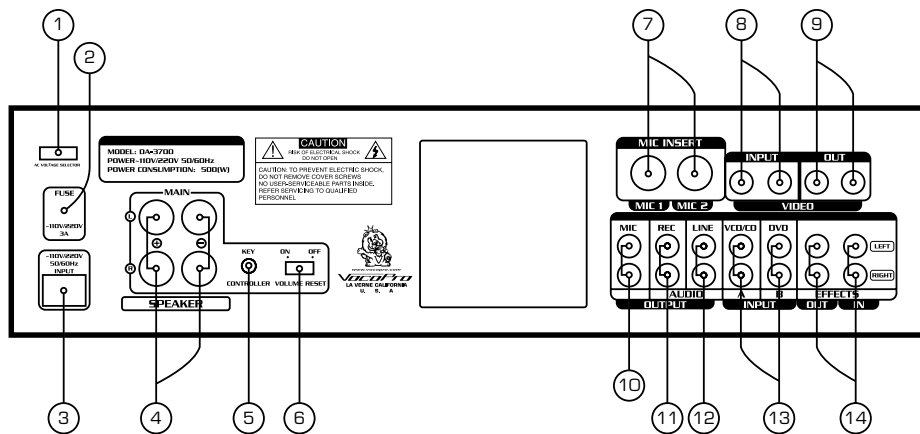

1. VOLTAGE SELECTOR switch – This selector toggles between 110-120V and 220-240V power settings. NOTE: Please ensure this toggle is set to the correct position, matching the receiving AC outlets power supply before plugging it in an operating it. Doing so may cause severe damage to the unit and void your product warranty.
2. FUSE terminal - This terminal houses the DA-3700 PRO's main system FUSE. NOTE: If fuse replacement is necessary, only replace with the same type and rating of fuse.
3. AC-IN terminal – Connect AC MAINS POWER CORD from the wall outlet to this terminal.
4. SPEAKER BINDING posts (MDP) – Connect appropriate speaker cables from these SPEAKER OUTPUT jacks to the INPUT jacks located on your speakers. Standard speaker wire or speaker cables equipped with MDP (banana) plugs can be used with the DA-3700 PRO's SPEAKER BINDING posts. NOTE: To use standard speaker wire, unscrew the plastic color-coded (red-black) binds until you can access the wire holes located on the inner-sides of the binds and slide the wire leads into them. Fasten them down by re-tightening the binds.
5. REMOTE KEY CONTROL - This 1/8" jack is for connecting a REMOTE KEY CONTROL cable. Remote Key Control allows you to make key changes at a distance from the Digital Key Controller on the DA-3700 PRO via controls on the microphone.
6. VOLUME RESET switch - The master MIC and MUSIC volumes on the DA-3700 PRO are programmed to reset back to zero every time the machine's power is turned off. The VOLUME RESET switch allows you to turn this feature off. When this switch is in the ON position, the volume will reset whenever the machine is turned off and when in the OFF position, the volume will stay the same when the machine is turned off.
7. MIC INSERT jacks - These 1/4" jacks allow you to loop each microphone line through an effects unit. NOTE: In order to do this you will need a 1/4" Y cable (not included). See "Connecting to an effects system using the Effects Loop" instructions in the GETTING CONNECTED section of this manual for further instructions on running vocals through an effects loop.
8. VIDEO INPUT (RCA) jacks - Connect RCA-ended video cables from these jacks to the VIDEO OUT jacks on the device connected to your VCD/CD (Input A) or DVD (Input B) player.
9. VIDEO OUTPUT (RCA) jacks - Connect RCA-ended video cables from these jacks to the VIDEO IN on a TV or display device. These are not independent outputs; they both output the same video signal simultaneously.
10. MIC OUTPUT jacks – These jacks output the two mic channels without any music. Connect a paired RCA-ended patch cable from these jacks to the appropriate INPUT jacks on a mixer or vocal effects unit. NOTE: MIC OUTPUT from these jacks is dry. Echo effects will not be applied to this MIC OUTPUT, regardless of the current master and channel echo settings.
11. REC OUTPUT jacks – These jacks provide connection to recording and other external audio devices. Connect a paired RCA-ended patch cable from these jacks to appropriate INPUT jacks on the recording or other audio/video device.
12. LINE OUTPUT jacks – These jacks output both mic channels and source music together.
13. AUDIO INPUT jacks - Input audio from a VCD/CD or DVD player into either of these channels. The audio from channel A can only be heard when channel A is selected on the DA-3700 PRO's input selector and the audio from channel B can only be heard when channel B is selected on the DA-3700 PRO's input selector.
14. EFFECTS LOOP jacks – Use the EFFECTS LOOP jacks to connect an external effects unit, such as a key controller or EQ. After removing the LOOP-BARS, connect a patch cable from the OUTPUT jacks of your external effects unit to the EFFECT LOOP IN jacks. Connect a second patch cable from the INPUT jacks of your external effects unit to the EFFECT LOOP OUT jacks on the DA-3700 PRO. NOTE: Do not discard the loop-bars. It is necessary for the loop-bars to be in place when there is no external effects unit being used.

# Remote control description

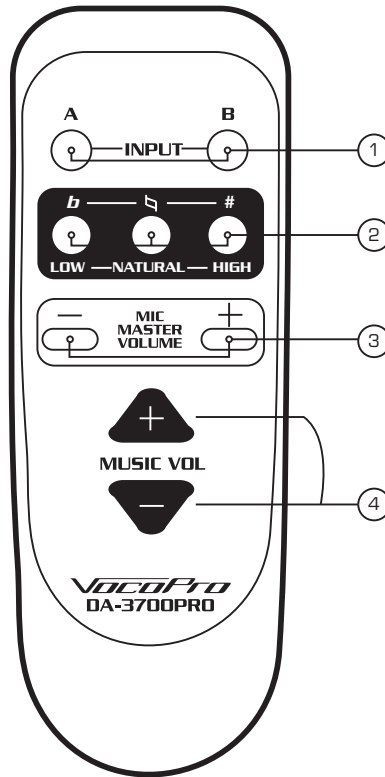

1. INPUT SELECTOR buttons - Use these buttons to toggle between the two available input channels A and B.
2. DIGITAL KEY CONTROL - Use these buttons to raise or lower the musical key of your source music (CD/DVD player). The LEDs indicate where the current key of the music is.
  - b - Lowers the key of the music
  -  - Restores the music back to its original (natural) key
  - # - Raises the key of the music
3. MIC MASTER VOLUME control - Use this to control the overall volume of both microphone channels. Turn clockwise to increase the master microphone volume and counter-clockwise to decrease the master microphone volume.
4. MUSIC MASTER VOLUME control - Use this to control the overall volume of the music from the CD/DVD player that is input into the DA-3700 PRO.

# Basic operations

## Switching between input channels

Use the A and B input buttons on the DA-3700 PRO's front panel or remote control to switch between the two input channels.

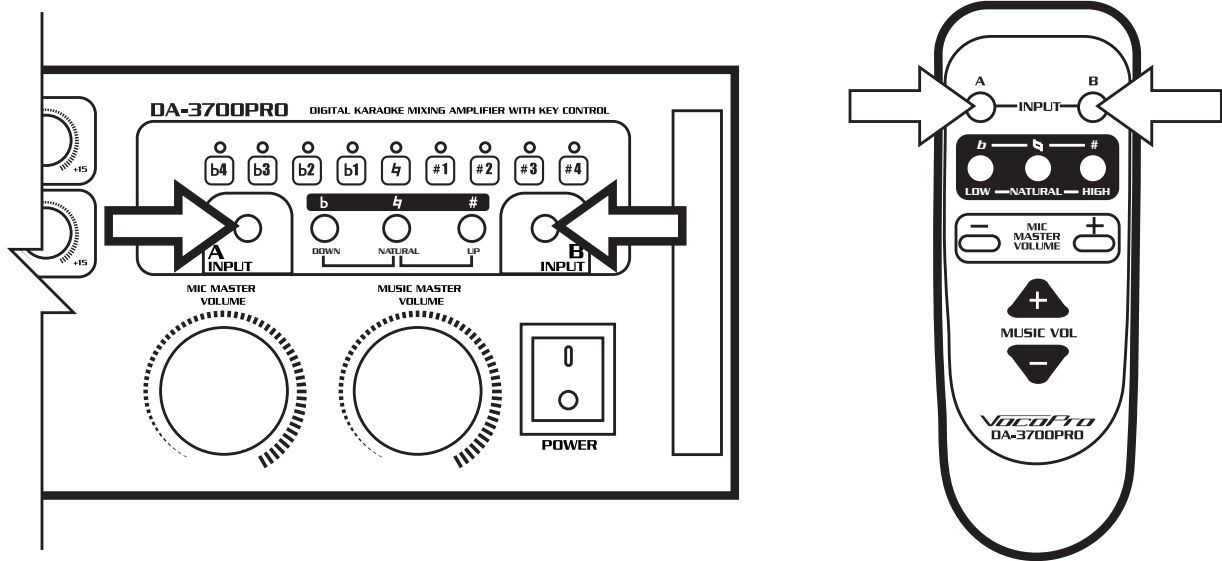

## Using Digital Key Control

Digital Key Control enables you to adjust the key of the source music (CD/DVD player) to fit the vocal range of the person who is singing. The key can be adjusted by using the key control buttons on the DA-3700 PRO's front panel, the remote control or from a Remote Key Control microphone.

- b - Lowers the key of the music
- ♯ - Resets the key back to its original (natural) state
- # - Raises the key of the music

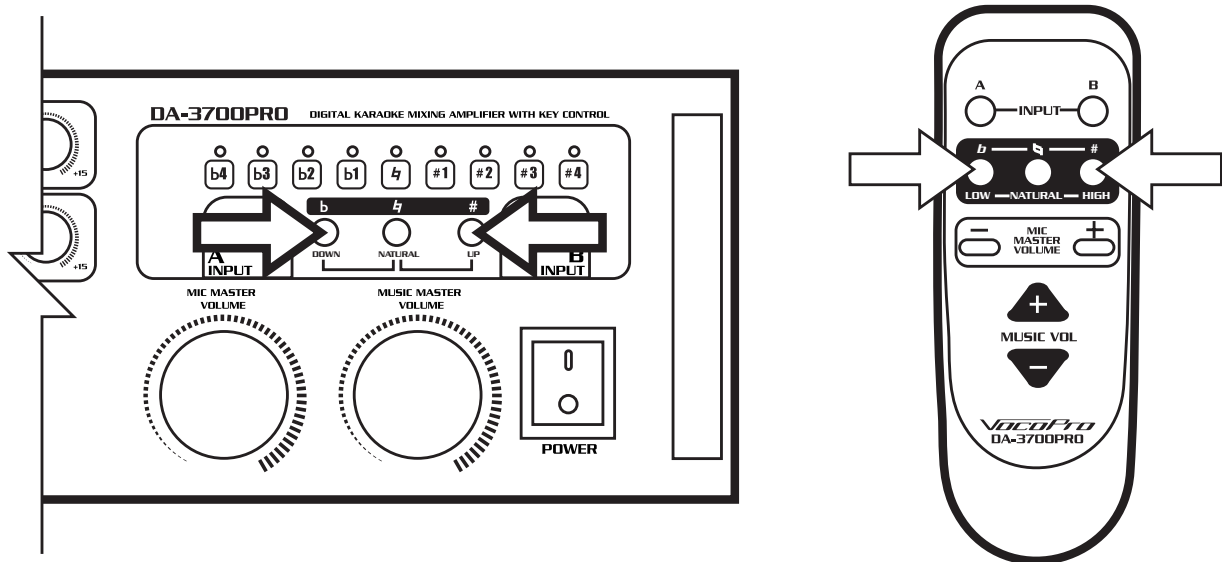

# Advanced operations

## Balancing the Music with the Vocals

The DA-3700 PRO has MASTER, HIGH, MID and LOW controls for both the music and the microphone levels, which enables you to adjust your mix levels with precision, resulting in a professional-sounding mix. If you find that the music is too loud, simply adjust the MUSIC VOLUME control. Also, keep in mind that HIGH, MID and LOW levels also affect the overall "sound" and can be adjusted to correct sound balancing problems. Excessive high (treble) frequencies can lead to feedback, so be careful when adjusting them.

## Balancing a Microphone Channel

When adjusting Mic levels, it is recommended to do so in this order:

1. First adjust the MIC VOLUME control to approximately 50%. (Shown on Fig. 1)
2. Then balance the LOW, MID and HIGH controls to approximately 40-60%. (Shown on Fig. 2)
3. Start background music with the MUSIC VOLUME set at approximately 50%. (Shown on Fig. 3)
4. Fine-tune each MIC CHANNEL as necessary till you get a clean balanced mix
5. Remember to compensate if the background music has striking volume changes. To do this, you can utilize the -20dB GAIN PAD. The -20dB Gain Pad toggles between a current volume level and reduced gain volume level. This control can be used to immediately go from one volume level to another by a quick push of the button.
6. Once all the settings are complete, do a complete song for complete balancing success.

**Fig. 1**

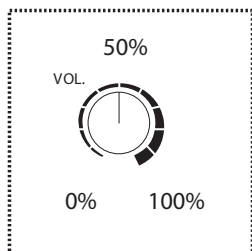

**Fig. 2**

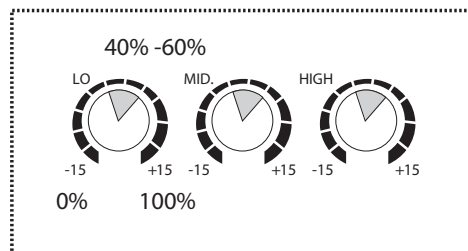

**Fig. 3**

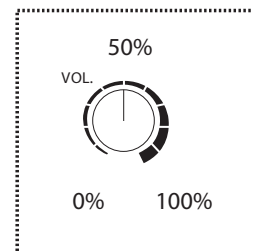

## Balancing the Music Channel

When adjusting the music levels follow the same procedure as seen above for Mic levels.



# Troubleshooting

PROBLEMS	CAUSE	SOLUTIONS
No sound coming from selected music source	Input Selector is set incorrectly.	Change Input Selector to the correct current playing source.
	Music Master Volume control is set to minimum.	Raise Music Master Volume to an appropriate level.
	The Effect Loop bars are either not inserted or inserted incorrectly; or the device connected to the Effect Loop is incorrectly working.	Connect the Loop Bars horizontally (L-OUT to L-IN and R-OUT to R-IN); or reconnect the connected device as stated in the instruction manual.
	Speakers and Speaker Cables are either not connected, loose or malfunctioning.	Check Speakers and Speaker Cable connections. Tighten or replace if necessary.
	Source player is functioning incorrectly.	Replace player and reset the DA-3700 PRO's power supply.
There are no graphics on the screen	Video cable(s) are not properly connected.	Reconnect cables firmly to correct video jacks as stated in the instruction manual.
	Disc medium is not a CDG.	Insert a CDG for playback.
	TV or monitor device is not set to the correct video setting.	Change TV or monitor settings to accept video.
High pitched squealing occurs when using the microphone	Microphone is pointed to, or is too close, to speakers.	Move microphone away from speakers.
	Treble level(s) are too high on the microphone channel(s).	Turn down treble level(s) on microphone channel(s).
No microphone output is present	The microphone is not turned on.	Turn on the microphone.
	The microphone cable is either loose or not functioning.	Tighten or replace the microphone cable.
	The Microphone Volume for that channel is set to a minimum.	Turn up the Microphone Volume for that channel.
	The microphone is not functioning correctly.	Replace the microphone.

# **VocoPro**<sup>®</sup>

---

**THE SINGER'S ULTIMATE CHOICE™**

